

NuTone ...life. style. home.



NuTone® is America's leading brand of residential built-in convenience products including door chimes, central vacuum systems, stereo intercom systems, home theater speakers, medicine cabinets, ironing centers and ventilation fans.

Broan® is America's leading brand of residential ventilation products including range hoods, ventilation fans, heater/fan/light combination units, Indoor Air Quality (IAQ) Fresh Air Systems, built-in heaters, whole-house fans, attic ventilators, paddle fans and trash compactors.

NuTone
life. style. home.™

www.NuTone.com

NuTone Inc., 4820 Red Bank Road, Cincinnati, OH 45227 • 888-336-3948
In Canada call 888-882-7626



NuTone
life. style. home.™

Medicine Cabinets



January 2007



Frameless

- 6 Metro Deluxe*
- 8 Metro Classic*
- 10 Metro Shapes
- 12 Metro Oversize*
- 14 Torino
- 14 Cameo Oval Bevel
- 15 Mirage
- 15 Sonata
- 16 Mirror-On-Mirror
- 16 Simplicity (oversized)▪
- 17 Styleline II*
- 17 Lafayette*
- 18 Focus*
- 18 Horizon
- 19 Quantum*
- 19 Vienna



Framed

- 21 Baker Street
- 22 Mission
- 23 Soho
- 24 Dunhill
- 25 Grant
- 25 Prairie
- 26 Canterbury
- 26 Chapel Hill
- 27 Oakdale*
- 27 Oakhill*
- 28 Grand Maple / Grand Oak
- 29 Kingston
- 30 Harmony (oversized)▪
- 31 Monaco (oversized)▪



Specialty

- 32 Illusion
- 33 Low Profile
- 33 Avanti Corner Cabinet
- 34 Centered Corner Cabinet
- 34 Modular Shelf
- 35 Stainless Steel Body
- 35 Bel Aire Auxiliary
- 36 Cabinet 455FL*
- 36 Cabinet 555IL*
- 37 Commodore
- 38 Beauty Glide (sliding doors)
- 38 Oak Hollywood* (sliding doors)
- 39 Flair* (sliding doors)
- 39 Ensign (sliding doors)



Basic

- 40 Styleline
- 41 Frameless Tri-View
- 42 The Prestique Series
- 43 Wood Frame with Top Light*
- 43 Wood Frame Cabinets
- 44 Louver Door
- 44 Hideaway
- 45 Drop Door Perfume Cabinet
- 45 Perfume Medicine Cabinet

Tastes are different. Styles are different. For that matter, budgets too. That's precisely why Broan-NuTone® offers such a breadth of medicine cabinet styles, finishes and functionality. We believe you shouldn't have to compromise when it comes to expressing yourself. After all, it's your home, and how you furnish it is a direct reflection of who you are. That's why we provide choices that build on your creativity, with options and accessories that will enhance your vision. Whether you're building or remodeling, our functional, fashionable storage solutions adapt to your style and complement the way you live. We have hundreds of ideas waiting for you, including one that is perfect for your home.

We have hundreds of fashionable medicine cabinets for one perfect bathroom. Yours.

* Winner of 2003 MVP Product Award, Building Products Magazine
 • These cabinets include built-in lighting
 ▪ Oversized cabinets feature a larger mirror and greater storage space



What do you need in a medicine cabinet? Perhaps it's a rich hardwood frame that complements the cabinetry in your home, or the ability to transform a simple wall into a model of organization. Maybe it's quality hinges that will hold up to the demands of a growing family, or an elegantly beveled mirror that provides a true reflection. With styles, sizes and an unsurpassed range of quality features matched to every budget, Broan-NuTone® has your medicine cabinet.



Shown: Metro Deluxe 52WH244DP
Winner of 2003 MVP Product Award, Building Products Magazine

Metro Deluxe

The Metro Collection meets the needs of discerning individuals who desire excellent craftsmanship, form and function at an affordable price. Metro Deluxe cabinets are available in a wide array of configurations including 25- and 35-inch heights, and 4- and 6-inch depths. All Metro Deluxe medicine cabinets feature internal mirrors and installation flexibility.



- A** Metro Deluxe 52WH346DP (34" tall, 6" deep with beveled mirror, recessed installation)
- B** Metro Deluxe 52WH244DPF (24" tall, 4" deep, recessed installation)
- C** Metro Deluxe 52WH244DPF (24" tall, 4" deep, surface mount installation with side mirror kit 760024)

Metro Deluxe



Shown: Metro Deluxe 52WH244DP

25" or 35" tall and 5" or 7" deep.

- Reversible installation allows right or left hand door opening.
- Exterior mirrors are premium float glass ensuring distortion-free viewing and a rich reflection. Available in both flat-front or beveled trim option — 1/2" bevel.
- Interior mirrors on the back of the cabinet and the inside door add light and functionality.
- Adjustable glass shelves provide light reflection, strength and easy cleaning. 24" models: 4 shelves, 34" models: 5 shelves.
- Snap-fit shelf supports ensure glass shelves stay in place, but can be easily removed for cleaning.
- 14-1/4" wide wall openings allow for easy retrofit installations or between studs for new construction.
- Fabricated steel construction features our durable rust-resistant finishing process.
- Corner bumpers cushion the door for a soft, quiet close.
- ISTA approved packaging provides safe shipment and handling.
- 170 degree concealed hinges allow wide door opening and smooth operation.

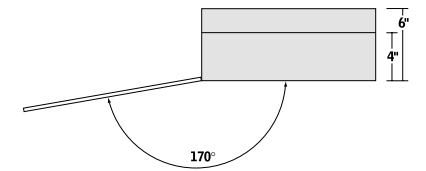

Model Number	Mirror Front	Frame Type	Door Type	Cabinet Depth	Mirror Shape	Overall Size w h d	Wall Opening w h d
Metro Deluxe Recessed and Surface Mount*							
52WH244DP	Bevel	Frameless	Single	4	Rectangle	15 25 5	14 1/4 24 4
52WH344DP	Bevel	Frameless	Single	4	Rectangle	15 35 5	14 1/4 34 4
52WH244DPF	Flat	Frameless	Single	4	Rectangle	15 25 5	14 1/4 24 4
52WH344DPF	Flat	Frameless	Single	4	Rectangle	15 35 5	14 1/4 34 4
52WH246DP	Bevel	Frameless	Single	6	Rectangle	15 25 7	14 1/4 24 6
52WH346DP	Bevel	Frameless	Single	6	Rectangle	15 35 7	14 1/4 34 6
52WH246DPF	Flat	Frameless	Single	6	Rectangle	15 25 7	14 1/4 24 6
52WH346DPF	Flat	Frameless	Single	6	Rectangle	15 35 7	14 1/4 34 6

All measurements are in inches.
 *Only models with a 4" depth can be surface mounted and require a Surface Mount Side Mirror Kit.

Surface Mount Side Mirror Kits (for 4" cabinet depths only)

- 760024 (for models 24" in height)
- 760034 (for models 34" in height)

Gangable Attachment Kit (for joining 2 or more cabinets in a row – see below)

- 76GK† (for both 24" and 34" models)

†To determine the quantity of Gang Kits needed, subtract 1 from the number of cabinets to be "ganged." When ganging cabinets that will be surface mounted, 1 Surface Mount Side Mirror Kit is needed for each cabinet. See Example 2.
 Example 1: Recess three cabinets in a row (3 cabinets - 1) = 2 Gangable Attachment Kits.
 Example 2: Surface mount four cabinets in a row (4 cabinets - 1) = 3 Gangable Attachment Kits, plus 4 Surface Mount Side Mirror Kits.



Gangable Attachment Kit(s) must be used when two or more cabinets are mounted side-by-side to ensure proper attachment and spacing. Cabinets can be "ganged" together in either recessed or surface-mount styles. Shown above, three Metro Deluxe (52WH244DP) cabinets joined by two Gangable Attachment Kits (76GK).

Metro Classic

Like its Deluxe sibling, Metro Classic provides flexible design solutions, outstanding features, and a transitional look that fits any décor.



A



B

A MetroClassic 52WH244PF (25" tall, 4" deep with flat mirror and side mirror kit 760024)

B MetroClassic 52WH344P (35" tall, 4" deep with beveled mirror)



Metro Classic



Shown: Metro Classic 52WH244P

25" or 35" tall in 5" depth only.

Reversible installation allows right or left hand opening.

Exterior mirrors are premium float glass ensuring distortion-free viewing and a rich reflection. Available in either flat-front or beveled trim option — 1/2" bevel.

Adjustable glass shelves provide superior light reflection, strength and easy cleaning. 24" models: 3 shelves, 34" models: 4 shelves.

Snap-fit shelf supports ensure shelves stay in place, but can be easily removed for cleaning.

14-1/4" wide wall openings allow for easy retrofit installations or between studs for new construction.

Fabricated steel construction features our durable rust-resistant finishing process.

Corner bumpers cushion the door for a soft, quiet close.

ISTA approved packaging provides safe shipment and handling.

125 degree concealed hinges allow wide door opening and smooth operation.

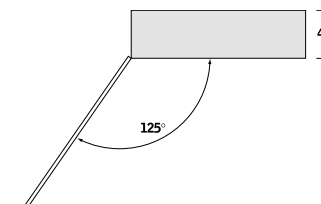

Gangable Attachment Kit(s) must be used when two or more cabinets are mounted side-by-side to ensure proper attachment and spacing. Cabinets can be "ganged" together in either recessed or surface-mount styles. Shown below, two Metro Classic (52WH244P) cabinets joined by one Gangable Attachment Kit (76GK).



Model Number	Mirror Front	Frame Type	Door Type	Cabinet Depth	Mirror Shape	Overall Size w h d	Wall Opening w h d
Metro Classic Surface and Recessed Mount*							
52WH244P	Bevel	Frameless	Single	4	Rectangle	15 25 5	14 1/4 24 4
52WH344P	Bevel	Frameless	Single	4	Rectangle	15 35 5	14 1/4 34 4
52WH244PF	Flat	Frameless	Single	4	Rectangle	15 25 5	14 1/4 24 4
52WH344PF	Flat	Frameless	Single	4	Rectangle	15 35 5	14 1/4 34 4

All measurements are in inches.

*Only models with a 4" depth can be surface mounted and require a Surface Mount Side Mirror Kit.

Surface Mount Side Mirror Kits (for 4" cabinet depths only)

760024 (for models 24" in height)

760034 (for models 34" in height)

Gangable Attachment Kit (for joining 2 or more cabinets in a row – see below)

76GK† (for both 24" and 34" models)

†To determine the quantity of Gang Kits needed, subtract 1 from the number of cabinets to be "ganged." When ganging cabinets that will be surface mounted, 1 Surface Mount Side Mirror Kit is needed for each cabinet. See Example 2.

Example 1: Recess three cabinets in a row (3 cabinets - 1) = 2 Gangable Attachment Kits.

Example 2: Surface mount four cabinets in a row (4 cabinets - 1) = 3 Gangable Attachment Kits, plus 4 Surface Mount Side Mirror Kits.

Metro Shapes

Tired of typical "square mirrors" on medicine cabinets? Well, so were we. That's what inspired us to create new Metro Shapes in a dramatic Oval, Arch and Octagon. With beveled front mirrors, Metro Shapes are beautifully functional, high quality cabinets. They're perfect over pedestal lavs in powder rooms, or in contemporary bathrooms where shapes add character, and make a statement about the room as well as the owner.



Metro Oval

Shown: Metro Oval 52WH184PV
(21-1/4" tall, 31-1/4" wide, recessed)

Metro Octagon



Shown: 52WH244PT

Metro Arch



Note: The Arch is hinged on the right side only.

- Exterior beveled mirrors ensure a deep, distortion-free, rich reflection.
- Interior mirrors on the back of the cabinet add light and functionality.
- Adjustable glass shelves provide light reflection, strength and easy cleaning.
- Metro **Arch** and **Octagon** feature three shelves; Metro **Oval** features two.
- Snap-fit shelf supports ensure glass shelves stay in place, but can be easily removed for cleaning.
- 14-1/4" wide wall openings allow for easy retrofit installations or between studs for new construction.
- Fabricated steel construction features a durable rust-resistant finish.
- Corner bumpers cushion the door for a soft, quiet close.
- ISTA approved packaging provides safe shipment and handling.
- Metro **Oval** and **Octagon** may be installed for left- or right-hand door opening.
- The **Arch** is right-hinged only.
- 125 degree concealed hinges on Metro **Octagon** and Metro **Arch** provide wide door opening and smooth operation.
- The Metro **Oval** features a piano hinge that opens 90 degrees.

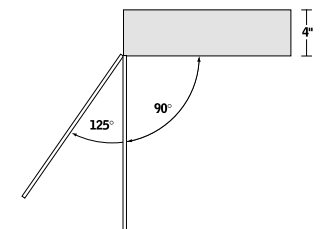

Model Number	Mirror Front	Frame Type	Door Type	Cabinet Depth	Mirror Shape	Overall Size w h d	Wall Opening w h d	Adj. Shelves
Metro Oval Recessed Mount								
52WH184PV	1" Bevel	Frameless	Single	4	Oval	21 31 4	14 18 3	2
Metro Arch Recessed or Surface Mount*								
52WH244PA	1/2" Bevel	Frameless	Single	4	Arch	15 31 5	14 24 4	3
Metro Octagon Recessed or Surface Mount*								
52WH244PT	1/2" Bevel	Frameless	Single	4	Octagon	15 31 5	14 24 4	3

*Surface mount installations require a Surface Mount Side Mirror Kit, Model Number 760024 (see page 9).
Note: All measurements are in inches.

Metro Oversize

Looking for more storage in your bathroom, but don't have much room? Do you prefer a single elegant mirror, rather than a medicine cabinet with two or three doors? If so, our Metro Oversize Series provides a tremendous amount of storage space in a simple and clean presentation. Our flat and beveled exterior mirror options will complement any décor.



Shown: Metro Oversize Classic 52WH304PF (30" tall, 24" wide, flat mirror, recessed)

Shown: Metro Oversize Deluxe 52WH304DP (30" tall, 24" wide, beveled mirror, recessed)



Metro Oversize

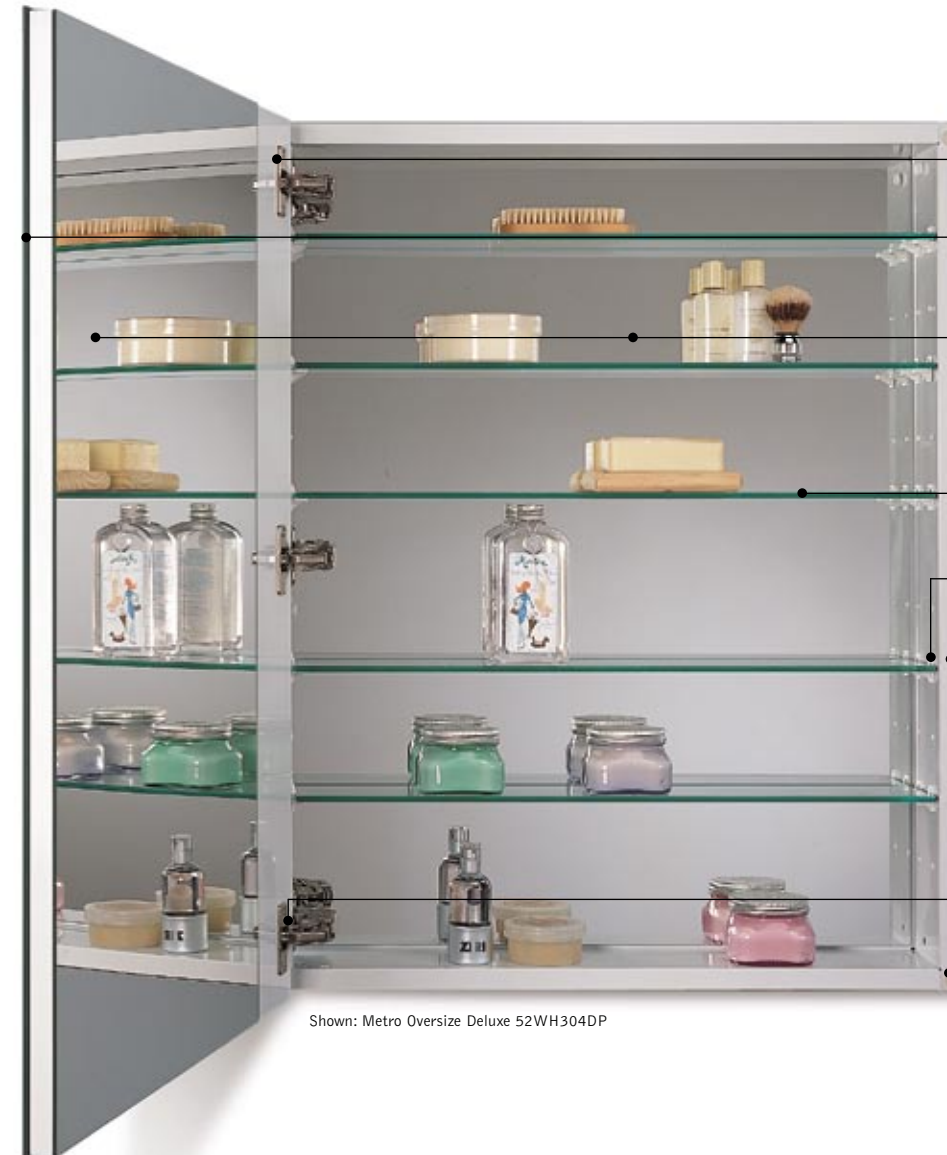

Shown: Metro Oversize Deluxe 52WH304DP

- 25" or 30" tall, and 5" deep.
- Reversible installation allows left- or right-hand door opening.
- Exterior mirror ensures a distortion-free, rich reflection and is available with either a flat front or 1/2" bevel.
- Metro Oversize **Deluxe** models feature interior mirrors on the door and cabinet back to add light and functionality.
- Metro Oversize **Classic** models feature a bright white enamel interior. See below.
- Adjustable glass shelves provide light reflection, strength and easy cleaning.
- Snap-fit shelf supports ensure glass shelves stay in place, but can be easily removed for cleaning.
- Fabricated steel construction features our durable rust-resistant finishing process.
- Corner bumpers cushion the door for a soft, quiet close.
- ISTA approved packaging provides safe shipment and handling.
- Concealed hinges allow wide door opening and smooth operation. Doors open:
 - 170 degrees on Metro Oversize **Deluxe**
 - 125 degrees on Metro Oversize **Classic**

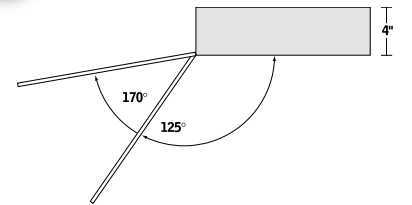

Model Number	Mirror Front	Frame Type	Door Type	Cabinet Depth	Mirror Shape	Overall Size w h d	Wall Opening w h d	Adj. Shelves
Metro Oversize Deluxe 20 x 25 Oversize Recessed or Surface Mount*								
52WH254DP	Bevel	Frameless	Single	4	Rectangle	20 25 5	19 1/4 24 4	4
52WH254DPF	Flat	Frameless	Single	4	Rectangle	20 25 5	19 1/4 24 4	4
Metro Oversize Deluxe 24 x 30 Oversize Recessed or Surface Mount*								
52WH304DP	Bevel	Frameless	Single	4	Rectangle	24 30 5	23 1/4 29 4	5
52WH304DPF	Flat	Frameless	Single	4	Rectangle	24 30 5	23 1/4 29 4	5
Metro Oversize Classic 24 x 30 Oversize Recessed or Surface Mount*								
52WH304P	Bevel	Frameless	Single	4	Rectangle	24 30 5	23 1/4 29 4	4
52WH304PF	Flat	Frameless	Single	4	Rectangle	24 30 5	23 1/4 29 4	4

*Surface mount installations require a Surface Mount Side Mirror Kit. See below.

Surface Mount Side Mirror Kit
 760025 (for Metro Oversize models 25" in height)
 760030 (for Metro Oversize models 30" in height)
 Note: All measurements are in inches.

Gangable Attachment Kit
 76GK*
 *To determine the quantity of Gang Kits needed, subtract 1 from the number of cabinets to be ganged. When ganging and surface mounting cabinets, 1 Surface Mount Side Mirror Kit is required for each cabinet.
 Example 1: Recess three cabinets in a row (3 cabinets - 1) = 2 Gangable Attachment Kits.
 Example 2: Surface mount four cabinets in a row (4 cabinets - 1) = 3 Gangable Attachment Kits, plus 4 Surface Mount Side Mirror Kits.

Shown: Metro Oversize Classic 52WH304PF, 30" H x 24" W

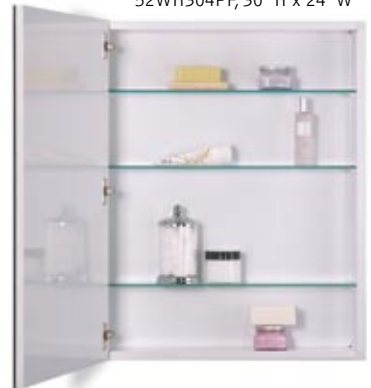

Torino



Shown: Torino 5528

The Torino features a beveled edge and frosted cut-glass arched design that's ideal over "his-and-hers" vanities or dual pedestal lavatories. Optional side light fixtures match the look with beveled-edge mirror backplates and a frosted glass shade.



Shown: 73591 side light kit

Cameo Oval Bevel



Shown: Cameo 1350

The Cameo Oval brings a touch of elegance to any room. Its frameless, 1" beveled-edge premium float glass mirror is supported by heavy-gauge steel construction. Adjustable shelves and a convenient reversible door are included in this perfect complement for powder rooms and pedestal lavatories.

Mirage



Shown: Mirage 1454 and optional 73190 side light kit (inset)

Like a multi-faceted gemstone, the octagonal Mirage mirror is framed in a 1/2" beveled edge. Optional sidelights with clear glass shades feature the same beveled-edge mirror treatment on rectangular backplates.

Sonata



Shown: Sonata 258 with optional 72052 side light kit

Sonata's graceful top and bottom curves combined with a 1/2" beveled-edge mirror create an elegant focal point. Matching optional side light fixtures feature a beveled-edge mirror backplate and distinctive frosted shades with chrome-plated fittings.

Model Number	Frame Type	Door Type	Mirror Shape	Overall Size			Wall Opening			Side Light Kit			
				w	h	d	w	h	d	Model #	w	h	d
Torino Recessed Mount													
5528	Frameless	Single	Arch	16½	34¼	4¾	14	24	3¾	73591*	6½	13¾	5¾
Cameo Recessed Mount													
1350	Frameless	Single	Oval	21	31	—	14	18	3¾				
1358	Frameless	Single	Oval	24	36	—	14	24	3¾				

Note: All measurements are in inches.
* Side lights packed in pairs.

Model Number	Frame Type	Door Type	Mirror Shape	Overall Size			Wall Opening			Side Light Kit			
				w	h	d	w	h	d	Model #	w	h	d
Mirage Recessed Mount													
1454	Frameless	Single	Octagon	18	27	4¾	14	18	3¾	73190*	5	12	6½
1456	Frameless	Single	Octagon	17¾	32	—	14	24	3¾				
Sonata Recessed Mount													
258	Frameless	Single	Arch	16	32	—	14	24	3¾	72052*	5	17¾	6¾

Note: All measurements are in inches.
* Side lights packed in pairs.

Mirror-On-Mirror



Shown: Mirror-On-Mirror 1450BC

Contemporary Mirror-On-Mirror designs create a classic, upscale look. Both models feature a clear center mirror with a 1/2" beveled-edge grey background mirror for an all-glass, picture frame effect.

Simplicity



Shown: Simplicity 530924

At times a name says everything. Simplicity unites a frameless beveled-edge mirror and a large viewing area. This oversized cabinet provides more storage room when space is at a premium.

Oversized
24" wide

Styleline II



Shown: Styleline II 565

The Styleline II features chrome-plated steel trim on the top and bottom, with polished vertical edges. A built-in top light includes a chrome-plated steel faceplate.

Lafayette



Shown: Lafayette 1402 with round corners

The Lafayette offers a choice of beveled-edge mirror designs to suit your decorating preferences. Both square and radius corner styles feature built-in top lights.

Shown: 73190 side light kit



Shown: Mirror-On-Mirror 1452 with optional 73290 top light kit

Model Number	Frame Type	Door Type	Mirror Shape	Overall Size			Wall Opening			Top Light Kit			Side Light Kit				
				w	h	d	w	h	d	Model #	w	h	d	Model #	w	h	d
Mirror-On-Mirror Recessed Mount																	
1450BC	Frameless	Single	Rectangle	16	26	5	14	18	3 1/2	73290	16	4 1/2	2	73190*	5	12	6 1/2
1452	Frameless	Single	Oval	16	26	5	14	18	3 1/2	73290	16	4 1/2	2	73190*	5	12	6 1/2

Simplicity Recessed Mount, oversized

530924	Frameless	Single	Rectangle	24	30	4 1/2	21 1/2	27 1/2	3 1/2
--------	-----------	--------	-----------	----	----	-------	--------	--------	-------

Note: All measurements are in inches.

* Side lights packed in pairs.

Model Number	Frame Type	Door Type	Mirror Shape	Overall Size		
				w	h	d
Styleline II Surface Mount with Built-In Top Light						
565	Chrome*	Single	Rectangle	18	28	4 1/4

Lafayette Surface Mount with Built-In Top Light

1402	Frameless	Single	Rectangle, round corner	18 1/2	32 1/2	4 1/4
1462	Frameless	Single	Rectangle, square corner	18 1/2	28 1/2	4 1/4

Note: All measurements are in inches.

* Chrome-plated steel trim.

■ Cabinet depth does NOT include light bulbs or the socket.



Shown: Lafayette 1462 with square corners

Focus



Shown: Focus 295230 and Focus 1430 (inset)

Simple, clean polished-edge design enables this tri-view mirror with built-in top lights to complement a wide range of decorating styles.

Horizon



Shown: Horizon 255230 with H033090 top light kit, and 1453 (inset)

Horizon features the quiet elegance of beveled-edge design. A wide selection of tri-view and single-door models with optional matching light bars make this classic model a good fit for any size room or décor.

Quantum



Shown: Quantum 455236

Beveled-edge elegance with a rounded corner design makes the Quantum tri-view ideal for use with any decorative motif.

Vienna



Shown: Vienna 155130 with SB23129 top light kit

Our economical steel-body tri-view cabinet, the Vienna, features a contemporary design framed in polished chrome-plated steel. The matching optional top light has a polished stainless steel faceplate.

Tri-view medicine cabinet mirrors open as shown below. Door configuration cannot be changed.

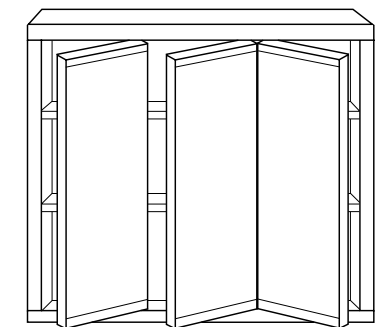

Model Number	Frame Type	Door Type	Mirror Shape	Overall Size			Wall Opening			Top Light Kit			Side Light Kit				
				w	h	d	w	h	d	Model #	w	h	d	Model #	w	h	d
Focus Recessed Mount																	
1430	Frameless	Single	Rectangle	16	22	4 3/4	14	18	3 1/2								
1433*	Frameless	Single	Rectangle	16 1/2	20 1/2	—	14	18	2 1/2								
1438	Frameless	Single	Rectangle	16	26	—	14	24	3 1/2								
Focus Surface Mount with Built-In Top Lights																	
295224■	Frameless	Tri-View	Rectangle	24	30	5 1/2	—	—	—	Built-In							
295230■	Frameless	Tri-View	Rectangle	30	34	5 1/2	—	—	—	Built-In							
Horizon Recessed Mount																	
1451	Frameless	Single	Rectangle	16	26	4 3/4	14	18	3 1/2	73290**	16	4 1/2	2	73190†	5	12	6 1/2
1453*	Frameless	Single	Rectangle	16 1/2	20 1/2	—	14	18	2 1/2	73290**	16	4 1/2	2	73190†	5	12	6 1/2
1453ADJ*	Frameless	Single	Rectangle	16 1/2	20 1/2	—	14	18	2 1/2	73290**	16	4 1/2	2	73190†	5	12	6 1/2
1459	Frameless	Single	Rectangle	16	26	4 3/4	14	24	3 1/2	73290**	16	4 1/2	2	73190†	5	12	6 1/2
610BC*	Frameless	Single	Rectangle	16 1/2	22 1/2	3 1/4	14	18	2 1/2	73290**	16	4 1/2	2	73190†	5	12	6 1/2
255024	Frameless	Tri-View	Rectangle	24	24	5	21 1/2	20 1/2	3 1/2	H042490	24	4 1/2	2 1/2				
255030	Frameless	Tri-View	Rectangle	30	28 1/2	5	27 1/2	24 1/2	3 1/2	H043090	30	4 1/2	2 1/2				
255036	Frameless	Tri-View	Rectangle	36	28 1/2	5	33 1/2	24 1/2	3 1/2	H043690	36	4 1/2	2 1/2				
255048	Frameless	Tri-View	Rectangle	48	28 1/2	5	45 1/2	24 1/2	3 1/2	H044890	48	4 1/2	2 1/2				
Horizon Surface Mount																	
255224■	Frameless	Tri-View	Rectangle	24	24	5 1/2	—	—	—	H032490	24	4 1/2	5 1/2				
255236■	Frameless	Tri-View	Rectangle	36	28 1/2	5 1/2	—	—	—	H033690	36	4 1/2	5 1/2				
255248■	Frameless	Tri-View	Rectangle	48	28 1/2	5 1/2	—	—	—	H034890	48	4 1/2	5 1/2				

Note: All measurements are in inches.
* Molded body.

† Side lights packed in pairs. See inset photo on page 16.
** See inset photo on page 16.

■ Cabinet depth does NOT include light bulbs or the socket.

Model Number	Frame Type	Door Type	Mirror Shape	Overall Size			Top Light Kit
				w	h	d	
Quantum Surface Mount with Built-In Top Lights							
455230■	Frameless	Tri-View	Rectangle	30	36 1/2	5 1/2	Built-in
455236■	Frameless	Tri-View	Rectangle	36	36 1/2	5 1/2	Built-in
455248■	Frameless	Tri-View	Rectangle	48	36 1/2	5 1/2	Built-in
Vienna Surface Mount							
155124■	Chrome*	Tri-View	Rectangle	24	26	5 1/2	SB22529 24 4 5 1/2
155130■	Chrome*	Tri-View	Rectangle	30	26	5 1/2	SB23129 30 4 5 1/2

Note: All measurements are in inches.

* Chrome-plated steel trim.

■ Cabinet depth does NOT include light bulbs or the socket.

Many consumers desire the storage and functionality of a medicine cabinet but want the look of a fashion frame mirror, or a simple frame and lighting. No matter the need, we have lots of ideas for you. To complement the colors, styles and textures in your home, we offer a wide selection of framed cabinets. Our rich hardwoods, contemporary metals, and ornate frames unite the architectural features and accessories in your bath or powder room.



Shown: Mission 9000C, see page 22 for details.



Baker Street



Shown: Baker Street 830C

Shown: Baker Street 870 with 70373 top light kit



Shown: 824BC with 70324 top light kit



We've captured the Victorian era in our Baker Street series with distinctive and practical solutions to bathroom storage. Choose from a classic white painted hardwood, warm honey-finished solid oak, solid cherry or solid maple frames. Optional light fixtures feature frosted glass shades and bright brass fittings.

Model Number	Frame Type	Door Type	Mirror Shape	Overall Size			Wall Opening			Top Light Kit			
				w	h	d	w	h	d	Model #	w	h	d
Baker Street Recessed Mount													
830C	Cherry	Single	Arch	17 ¹ / ₁₆	33 ³ / ₄	—	14	24	3 ¹ / ₂				
820	White	Single	Rectangle	18	27 ¹ / ₄	—	14	18	3 ¹ / ₂	70323	18	8	9
828	White	Single	Rectangle	18	27 ¹ / ₄	—	14	24	3 ¹ / ₂	70323	18	8	9
824BC	Maple	Single	Rectangle	18	27 ¹ / ₄	—	14	24	3 ¹ / ₂	70324	18	8	9
870	Honey Oak	Single	Rectangle	18	27 ¹ / ₄	—	14	18	3 ¹ / ₂	70373	18	8	9
878BC	Honey Oak	Single	Rectangle	18	27 ¹ / ₄	—	14	24	3 ¹ / ₂	70373	18	8	9
Baker Street Surface Mount													
822	White	Single	Rectangle	18	27 ¹ / ₄	5	—	—	—	70223	18	8	13 ¹ / ₂
872BC	Honey Oak	Single	Rectangle	18	27 ¹ / ₄	5	—	—	—	70273	18	8	13 ¹ / ₂
842230	White	Tri-View	Rectangle	30	28 ¹ / ₂	5 ¹ / ₂	—	—	—	BS84023	30	6	6 ¹ / ₂
842236	White	Tri-View	Rectangle	36	28 ¹ / ₂	5 ¹ / ₂	—	—	—	BS84623	36	6	6 ¹ / ₂

Note: All measurements are in inches.

Mission



Shown: Mission 9000C

The Mission, in its solid cherry wood frame and rich finish, features a beveled mirror and adjustable glass shelves. It's truly affordable fashion furniture for the bath or powder room.

Model Number	Frame Type	Door Type	Mirror Shape	Overall Size			Wall Opening		
				w	h	d	w	h	d
Mission Recessed Mount									
9000C	Cherry	Single	Designer	17 ³ / ₁₆	33 ³ / ₁₆	5 ¹ / ₂	14	24	3 ¹ / ₂

Note: All measurements are in inches.

Soho



Shown: Soho 850M

Framed in solid maple or cherry hardwoods, the Soho's transitional design works as well in a city loft as it does in a country cottage. Solid wood frames, rich wood tones, beveled mirrors and adjustable glass shelving address the needs of consumers and designers.

Model Number	Frame Type	Door Type	Mirror Shape	Overall Size			Wall Opening		
				w	h	d	w	h	d
Soho Recessed Mount									
850C	Cherry	Single	Rectangle	17 ³ / ₁₆	27 ¹ / ₁₆	-	14	24	3 ¹ / ₂
850M	Maple	Single	Rectangle	17 ³ / ₁₆	27 ¹ / ₁₆	-	14	24	3 ¹ / ₂

Note: All measurements are in inches.

Shown: Soho 850C in Cherry



Dunhill



Shown: Dunhill 1370

Shown: Dunhill 1370M



Shown: Dunhill 1370WH

Tired of square frames? Our Dunhill oval series is perfect over pedestal lavatories and could be used side-by-side over wider vanities. Whether you select the Dunhill framed in solid honey-finished oak, solid maple or in painted white wood, you'll find its simple elegance a natural fit in any bath or powder room.

Model Number	Frame Finish	Door Type	Mirror Shape	Overall Size			Wall Opening		
				w	h	d	w	h	d
Dunhill Recessed Mount									
1370	Honey Oak	Single	Oval	21	31	5½	14	18	3½
1370M	Maple	Single	Oval	21	31	5½	14	18	3½
1370WH	White Finish	Single	Oval	21	31	5½	14	18	3½

Note: All measurements are in inches.

Grant



Shown: Grant 8778 with 74279 top light kit

Looking for a classic solid oak frame for almost any bath? The Grant, with its honey-oak finish and optional oak accessory top light kit, is ideal.

Model Number	Frame Type	Door Type	Mirror Shape	Overall Size			Wall Opening			Top Light Kit			
				w	h	d	w	h	d	Model #	w	h	d
Grant Recessed Mount													
8770	Honey Oak	Single	Rectangle	16¼	24¼	—	14	18	3½	74279	16¼	5½	3
8773*	Honey Oak	Single	Rectangle	16¼	22	—	14	18	2½	74279	16¼	5½	3
8778	Honey Oak	Single	Rectangle	16¼	26¼	—	14	24	3½	74279	16¼	5½	3
973BC*	Honey Oak	Single	Rectangle	16	20	—	14	18	2½	74279	16¼	5½	3

Grant Surface Mount												
8772	Honey Oak	Single	Rectangle	16¼	24¼	5½						

Prairie Recessed Mount													
8120	White	Single	Rectangle	17	27	—	14	18	3½	70928	17	8	8
8128	White	Single	Rectangle	17	27	—	14	24	3½	70928	17	8	8

Prairie Surface Mount												
8122	White	Single	Rectangle	17	27							

Note: All measurements are in inches.

* Molded body.

■ Cabinet depth does NOT include light bulbs or the socket.

Prairie



Shown: Prairie 8120 with 70928 top light kit

Classic design comes alive in the painted white wood of the Prairie. It's striking when displayed alone or in pairs.

Canterbury



Shown: Canterbury 8570 with 76378 top light kit

The traditional arch design of the Canterbury adds a touch of elegance at an affordable price point. The solid oak frame, optional top lights with glass shades and brass fittings welcome everyone to your home.

Chapel Hill



Shown: Chapel Hill 8278

Southern charm abounds in the Chapel Hill. Unassuming in design, its solid oak, honey-finished frame features rounded-edge styling that helps soften the look of any bath or powder room.

Oakdale



Shown: Oakdale 2072

The Oakdale is a remarkably efficient cabinet. With integral lighting, installation is an easy, one-step process. Framed in solid oak with a warm honey oak finish, the Oakdale is comfortable in traditional and contemporary settings.

Oakhill



Shown: Oakhill 177930

Classically shaped edges and a solid oak, honey-finished frame make the Oakhill a traditional favorite. Attached top lights facilitate easier recessed or surface-mount installation, and the reflective lighting panel directs light into the room.

Model Number	Frame Type	Door Type	Mirror Shape	Overall Size			Wall Opening			Top Light Kit			
				w	h	d	w	h	d	Model #	w	h	d
Canterbury Recessed Mount													
8570	Honey Oak	Single	Arch	18	27½	–	14	18	3½	76378	18	8	8
Canterbury Surface Mount													
8572	Honey Oak	Single	Arch	18	27½	–	–	–	–	76478	18	8	11½
Chapel Hill Recessed Mount													
8278	Honey Oak	Single	Rectangle	17¼	27¼	–	14	24	3½				

Note: All measurements are in inches.

Model Number	Frame Type	Door Type	Mirror Shape	Overall Size			Wall Opening		
				w	h	d	w	h	d
Oakdale Recessed or Surface Mount with Built-In Top Light									
2072	Honey Oak	Single	Rectangle	17¼	29	4¼	16½	27½	3½
Oakhill Recessed or Surface Mount with Built-In Top Light									
177924	Honey Oak	Tri-View	Rectangle	23¼	29	4¼	22½	27½	3½
177930	Honey Oak	Tri-View	Rectangle	29¼	29	4¼	28½	27½	3½
177936	Honey Oak	Tri-View	Rectangle	35¼	29	4¼	34½	27½	3½
177948	Honey Oak	Tri-View	Rectangle	47¼	29	4¼	46½	27½	3½

Note: All measurements are in inches.

■ Cabinet depth does NOT include light bulbs or the socket.

Grand Maple



Shown: Grand Maple 277936M

Kingston



Shown: Kingston 8378 with 71829 top light kit

Shown: Grand Oak 277936



Our popular tri-view medicine cabinet is now available in contemporary natural-finished solid maple and warm honey-finished solid oak. Both the Grand Maple and Grand Oak can be recessed or surface mounted.

The Kingston's shadow box appearance is achieved with its fine solid oak frame and beveled mirror. These features add dimension to this unique cabinet, finished in a warm honey oak color. Add an optional top light that matches the cabinet when more illumination is needed.

Model Number	Frame Type	Door Type	Mirror Shape	Overall Size			Wall Opening		
				w	h	d	w	h	d
Grand Oak/Grand Maple Recessed or Surface Mount									
277936	Honey Oak	Tri-View	Rectangle	35 ¹³ / ₁₆	29	4 ¹ / ₄	34 ¹ / ₂	27 ¹ / ₂	3 ¹ / ₂
277948	Honey Oak	Tri-View	Rectangle	47 ¹³ / ₁₆	29	4 ¹ / ₄	46 ¹ / ₂	27 ¹ / ₂	3 ¹ / ₂
277936M	Maple	Tri-View	Rectangle	35 ¹³ / ₁₆	29	4 ¹ / ₄	34 ¹ / ₂	27 ¹ / ₂	3 ¹ / ₂

Note: All measurements are in inches.

Model Number	Frame Type	Door Type	Mirror Shape	Overall Size			Wall Opening			Top Light Kit			
				w	h	d	w	h	d	Model #	w	h	d
Kingston Recessed Mount													
8378	■ Honey Oak	Single	Rectangle	16 ¹ / ₂	26 ¹ / ₂	–	14	24	3 ¹ / ₂	71829	16 ¹ / ₂	5 ¹ / ₂	2 ¹ / ₄

Note: All measurements are in inches.

■ Cabinet depth does NOT include light bulbs or the socket.

Harmony



Shown: Harmony 533124

The Harmony, one of our oversized cabinets, is designed for greater storage room where single door design is preferred. Its transitional chrome-tone anodized aluminum frame resists humidity and cleans easily. And its larger size brings an equally generous viewing area.

Oversized
24" wide

Model Number	Frame Type	Door Type	Mirror Shape	Overall Size			Wall Opening		
				w	h	d	w	h	d
Harmony Recessed Mount, oversized									
533124	Chrome-Tone	Single	Rectangle	24	30	5½	21½	27½	3½

Note: All measurements are in inches.

Monaco



Shown: Monaco 535224

The Monaco, with a gold-tone frame, is a work of art in any bath or powder room. Its sophisticated finish highlights the accents in faucets and other bathroom accessories. One of our oversized cabinets, it is designed with a larger viewing area and more storage room.

Oversized
24" wide

Model Number	Frame Type	Door Type	Mirror Shape	Overall Size			Wall Opening		
				w	h	d	w	h	d
Monaco Recessed Mount, oversized									
535224	Gold-Tone	Single	Rectangle	24	30	5½	21½	27½	3½

Note: All measurements are in inches.

The beautiful frame and oversized storage area make the Monaco a true piece of functional art for the bathroom.



The fabricated metal cabinet and durable anodized aluminum frame make the Harmony a logical choice in high use bathrooms with greater storage needs.



Whether you have a small space, a tight corner, or the need for storage where there's none to be found, our selection of specialty cabinets is a problem-solving showcase.

Illusion

To create the appearance of a continuous wall mirror, our recessed Illusion cabinets feature unique Eurostyle hinges that allow the door to close only 1/4" off the wall surface. It's the consummate solution to design simplicity.



Shown: Two Illusion 629 medicine cabinets with a 1/4" thick center mirror, and top and side mirror panels (purchased separately through your local glass company). NOTE: 1/4" thick mirrors are required to maintain the flush mount look between all mirrored surfaces.



The Illusion 629SS (shown above) with a fabricated stainless steel body offers a clean, sophisticated, modern look.

Model Number	Frame Type	Door Type	Mirror Shape	Overall Size			Wall Opening		
				w	h	d	w	h	d
Illusion Recessed Mount									
629	Frameless	Single	Rectangle	15	36	3/4	14	34 1/4	3 1/2
629SS	Frameless	Single	Rectangle	15	36	3/4	14	34 1/4	3 1/2
639BC	Frameless	Single	Rectangle	13	36	-	12	34 1/4	3 1/2
664	Frameless	Single	Rectangle	13	36	-	12	34 1/4	3 1/2

Note: All measurements are in inches.

Low Profile



Shown: Low Profile 663BC

Looking for a solution to sidewall storage that won't get in the way? The Low Profile is a perfect solution. With the mirrored door closed, the Low Profile sits just 3/4" off the wall surface.

Avanti Corner Cabinet



Shown: Two Avanti Corner Cabinets, model 631 (doors closed) with wall mirror mounted in between (purchased separately)

To increase the perception of light and space in a small alcove, use two Avanti Corner Cabinets with a wall mirror (purchased separately) mounted in between. You'll have three way viewing, and a generous storage space in a compact area.

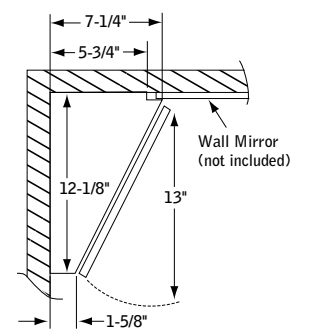

Top-down view of left hand Avanti 631 Corner Cabinet as shown in photo above.

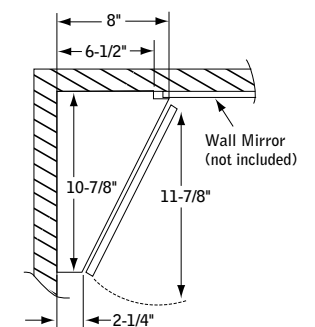

Top-down view of left hand Avanti 637 Corner Cabinet.

Model Number	Frame Type	Door Type	Mirror Shape	Overall Size			Wall Opening		
				w	h	d	w	h	d
Low Profile Recessed Mount†									
663BC	Frameless	Single	Rectangle	15	36	3/4	12 1/2	34 1/4	3 1/2

Avanti Corner Cabinet Surface Mount									
631	Stainless Trim	Single	Corner Trim	13	36	7/8			
637*	Frameless	Single	Corner Trim	11 1/2	36	8			

Note: All measurements are in inches.
* Molded body.

Stainless Trim = Stainless steel trimmed frame.

† The Low Profile 663BC does not fit flush with wall mirrors.

Centered Corner Cabinet



Shown: Centered Corner Cabinet 672BC

Aligned over a corner vanity, the Centered Corner Cabinet adds visual height to small rooms. It's ideal when storage space is in short supply.

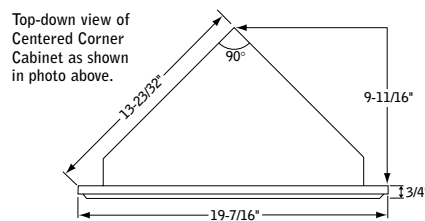

Note: All measurements are in inches.
Stainless = Stainless steel.

Modular Shelf



Shown: Modular Shelf 468MOD

The Modular Shelf puts an end to the problem of storing taller items and wasted space. This unique design maximizes capacity with six modular half-shelves that can be positioned in a variety of configurations. Shelves can be adjusted without tools to accommodate a broad variety of container shapes and sizes.

Model Number	Frame Type	Door Type	Mirror Shape	Overall Size			Wall Opening		
				w	h	d	w	h	d
Centered Corner Cabinet Surface Mount									
672BC	Honey Oak	Single	Corner Trim	19½	33½	10½			
672SS	Stainless	Single	Corner Trim	17¼	31	9¾			
Modular Shelf Recessed Mount									
468MOD	Stainless	Single	Rectangle	16	26	—	14	24	3½

Note: All measurements are in inches.
Stainless = Stainless steel.

Stainless Steel Body



Shown: Stainless Steel Body 1448

This easy-to-clean, corrosion-resistant single-door cabinet features high luster, stainless steel construction and a bright satin finish. Combined with a 1/2" beveled-edge door mirror, the Stainless Steel Body provides a high-tech look at a modest price.

Model Number	Frame Type	Door Type	Mirror Shape	Overall Size			Wall Opening		
				w	h	d	w	h	d
Stainless Steel Body Recessed Mount									
1447	Frameless	Single	Rectangle	16	20	—	14	18	3½
1448	Frameless	Single	Rectangle	16	26	—	14	24	3½
Bel Aire Auxiliary Recessed Mount									
625	Stainless Trim	Single	Rectangle	13	36	—	11¼	33¾	3½
Bel Aire Auxiliary Surface Mount									
626	Stainless Trim	Single	Rectangle	13	36	4¾			

Note: All measurements are in inches.
Stainless Trim = Stainless steel trimmed frame.

Bel Aire Auxiliary



Shown: Two Bel Aire Auxiliary 626 cabinets with a PEM3036 wall mirror mounted in between (see page 37)

The Bel Aire Auxiliary provides excellent storage. Stainless steel trim on door tops and bottoms plus polished vertical mirror edges complete the classic presentation.



Shown: Bel Aire Auxiliary 625

Cabinet 455FL



Shown: Cabinet 455FL

The Cabinet 455FL is a one-piece steel storage solution with integral fluorescent side lights, a grounded outlet and an on-off switch. If you need a timeless design, easy installation, storage and lighting, the 455FL is your answer.

Model Number	Frame Type	Door Type	Mirror Shape	Overall Size			Wall Opening		
				w	h	d	w	h	d
Cabinet 455FL Recessed Mount with Built-In Side Lights									
455FL	Stainless	Single	Rectangle	20"	22"	3"	14"	19"	7"
Cabinet 555IL Surface Mount with Built-In Top Light									
555IL	Stainless	Single	Rectangle	16"	24"	8"			

Note: All measurements are in inches. Stainless = Stainless steel.

Cabinet 555IL



Shown: Cabinet 555IL

The surface-mounted Cabinet 555IL has a stainless steel mirror frame and trim, plus a built-in light, a grounded outlet and an on-off switch.

Commodore



Shown: Commodore VM224M



Shown: Commodore PEM3024 wall mirror, V30 storage cabinet, and IL30 light kit

Whether you select the convenient combination unit or individual components to suit your needs, the stainless steel Commodore guarantees durable versatility. Channeled components allow easy installation, and light fixtures include a grounded outlet and switch. Mirrors feature polished edges and copper backing. It's a classic look that's back.

Model Number	Frame Type	Door Type	Mirror Shape	Overall Size			Top Light Kit			
				w	h	d	Model #	w	h	d
Commodore Combination Mirror and Cabinet										
VM224M	Stainless	Mirror	Rectangle	24"	32"	4"				
VM224P	Stainless	Styrene	Rectangle	24"	32"	4"				
VM230M	Stainless	Mirror	Rectangle	30"	32"	4"				
VM230P	Stainless	Styrene	Rectangle	30"	32"	4"				
VM236M	Stainless	Mirror	Rectangle	36"	32"	4"				
VM236P	Stainless	Styrene	Rectangle	36"	32"	4"				
Commodore Wall Mirror Only										
PEM2424	-	-	-	24"	24"	-	IL24	24"	4"	7"
PEM3024	-	-	-	30"	24"	-	IL30	30"	4"	7"
PEM3036	-	-	-	30"	36"	-	IL30	30"	4"	7"
PEM3624	-	-	-	36"	24"	-				
PEM3636	-	-	-	36"	36"	-				
PEM4824	-	-	-	48"	24"	-				
PEM4836	-	-	-	48"	36"	-				
PEM6036	-	-	-	60"	36"	-				
Commodore Storage Cabinet Only										
V24	-	Mirror	Rectangle	24"	8"	4"	IL24	24"	4"	7"
V30	-	Mirror	Rectangle	30"	8"	4"	IL30	30"	4"	7"
V36	-	Mirror	Rectangle	36"	8"	4"				
V48	-	Mirror	Rectangle	48"	8"	4"				

Note: All measurements are in inches. Stainless = Stainless steel.

Beauty Glide



Shown: Beauty Glide SB330

Beauty Glide represents functional simplicity. This polished stainless steel slider has two flat-front mirror doors, a white powder coat finish, and two adjustable shelves. If swinging doors get in the way, we have a beautiful solution.

Oak Hollywood



Shown: Oak Hollywood 2471IL

The Oak Hollywood features a solid oak frame in a honey finish and a matching wood-tone exterior that surrounds an integral incandescent top light, a grounded outlet, an on-off switch and clear handles on sliding doors.

Flair



Shown: Flair 323LP

Who says economical solutions can't come with quality? The Flair includes quality features like an incandescent built-in top light, stainless steel trim and an on-off switch. It's a self-contained, economical solution to bathroom storage and lighting necessity.

Ensign



Shown: Ensign 124LP

Originally designed for Navy barracks, the Ensign is functional utility, pure and simple. It features stainless steel trim and a built-in incandescent top light, sliding doors, a convenient grounded outlet and an integral on-off switch. Easy to install and use, it will help you keep everything ship-shape.

Model Number	Frame Type	Door Type	Mirror Shape	Overall Size			Wall Opening		
				w	h	d	w	h	d
Beauty Glide Recessed Mount									
SB330	Stainless	Slider	Rectangle	31 $\frac{1}{2}$	21 $\frac{1}{2}$	5 $\frac{1}{4}$	30 $\frac{3}{4}$	19 $\frac{1}{4}$	3 $\frac{1}{2}$
Oak Hollywood Surface Mount with Built-In Top Light									
2471IL	Honey Oak	Slider	Rectangle	24 $\frac{3}{4}$	24 $\frac{1}{2}$	9			
2871IL	Honey Oak	Slider	Rectangle	28 $\frac{3}{4}$	24 $\frac{1}{2}$	9			

Note: All measurements are in inches. Stainless = Stainless steel.

Model Number	Frame Type	Door Type	Mirror Shape	Overall Size		
				w	h	d
Flair Surface Mount with Built-In Top Light						
323LP	Stainless	Slider	Rectangle	24	19 $\frac{1}{2}$	7 $\frac{1}{2}$
327LP	Stainless	Slider	Rectangle	28	19 $\frac{1}{2}$	7 $\frac{1}{2}$
Ensign Surface Mount with Built-In Top Light						
124LP	Stainless	Slider	Rectangle	24	23 $\frac{1}{2}$	8 $\frac{1}{4}$
128LP	Stainless	Slider	Rectangle	28	23 $\frac{1}{2}$	8 $\frac{1}{4}$

Note: All measurements are in inches. Stainless = Stainless steel.

Sometimes expenses govern your purchase decisions. Our Basic Series is geared to this concern. Feature for feature, and dollar for dollar, you'll find the right balance of quality, style and value right here.

Styleline

Styleline is all about options. It's our classic, single-door cabinet series that comes in a broad range of sizes in both steel and molded cabinet bodies.



Shown: Styleline 452SM

Model Number	Frame Type	Door Type	Mirror Shape	Mirror Thickness	Overall Size			Wall Opening		
					w	h	d	w	h	d
Styleline Recessed Mount										
401ADJ*	Stainless	Single	Rectangle	3/32	16	20	3/4	14	18	2 1/2
405BP [■]	Stainless	Single	Rectangle	3/32	16	22	—	14	18	3
407ADJ*	Stainless	Single	Rectangle	3/32	16	22	3/4	14	18	2 1/2
420BC	Stainless	Single	Rectangle	1/16	16	22	—	14	20	3 1/2
421BC	Stainless	Single	Rectangle	3/8	16	22	—	14	20	3 1/2
449BC*	Stainless	Single	Rectangle	3/32	16	22	—	14	18	2 1/2
458	Stainless	Single	Rectangle	1/8	16	26	—	14	24	3 1/2
468BC	Stainless	Single	Rectangle	1/16	16	26	—	14	24	3 1/2
470FS**	Stainless	Single	Rectangle	3/32	16	26	5/4	14	24	3 1/2
473FS**	Stainless	Single	Rectangle	3/32	16	22	—	14	18	3 1/2
478FS**	Stainless	Single	Rectangle	1/8	16	26	5/4	14	24	3 1/2
490	Stainless	Single	Rectangle	1/8	18	24	—	16	21 1/2	3 1/2
495	Stainless	Single	Rectangle	1/8	20	30	—	17 1/4	26 1/4	3 1/2
624*	Stainless	Single	Rectangle	3/32	16	26	—	13 3/4	23 3/4	2 1/2
Styleline Surface Mount										
422SM	Stainless	Single	Rectangle	3/32	14	20	5/8			
452SM	Stainless	Single	Rectangle	3/32	16	22	5/8			
472FS**	Stainless	Single	Rectangle	3/32	16	22	—			
614*	Stainless	Single	Rectangle	3/32	16 1/4	22 1/4	4 1/4			

Note: All measurements are in inches. * Molded body. Stainless = Stainless steel. ** Meets Federal Spec #WW-P-541/8B. [■] Bulk Pack of two.

Frameless Tri-View



Shown: Frameless Tri-View 669730

An alternative to wood or metal, the plastic body of the Frameless Tri-View is durable and easy to clean. It's packed with features usually found only on higher-end cabinets: Beveled-edge mirrors, two fixed shelves in the center section, two adjustable shelves in each side section, and even one with a built-in toothbrush holder. In its category, the Frameless is peerless.

Model Number	Frame Type	Door Type	Mirror Shape	Overall Size			Wall Opening		
				w	h	d	w	h	d
Frameless Tri-View Surface Mount									
669730*	Frameless	Tri-View	Rectangle	30 1/4	24 1/4	5			

Note: All measurements are in inches. * Molded body.

Prestique — Solid Oak



A. Shown: Prestique 907236 with CR93679 top light kit

Prestique — Frameless Beveled-Edge



C. Shown: Prestique 905236 with CR93690 top light kit

Our versatile cabinets feature beautiful finishes in a variety of classic designs, all with ample storage capacities.

A, B Prestique cabinets, with solid honey-finished oak or painted white wood frames, feature a matching finish on the composite wood cabinet body. A matching top light for the oak model has a brass finish on the faceplate.

C If it suits your style, go frameless. Its beveled-edge mirror provides a contemporary look, with optional top lighting to complete the appearance.

Wood Frame With Built-In Top Light



Shown: Wood Frame 9472 with built-in top light

Wood Frame Cabinets



Shown: Wood Frame 967224

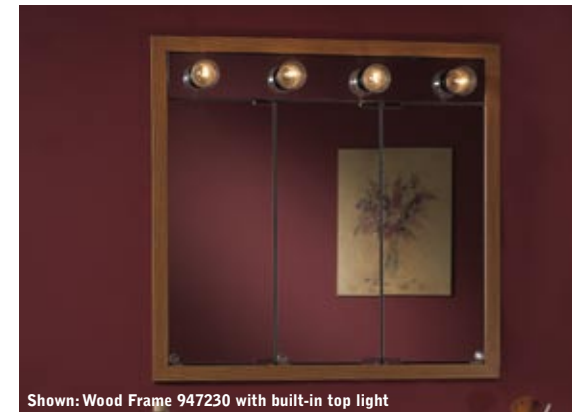

Shown: Wood Frame 947230 with built-in top light



Shown: Wood Frame 902WH

The integrated frame and lighting system of Wood Frame cabinets offer an upscale look at an economical price. Tri-view and single-door models feature wood frames with an oak or white finish and a polished chrome lighting faceplate.

If you prefer the component look, Wood Frame surface-mount, tri-view and single-door cabinets are available. Side panels match the frame finish for a coordinated look.

White Frame



B. Shown: Prestique 902236

Model Number	Frame Type	Door Type	Mirror Shape	Overall Size			Top Light Kit			
				w	h	d	Model #	w	h	d
A. Prestique Oak Surface Mount										
907224	Honey Oak	Tri-View	Rectangle	24	26	4 1/4				
907230	Honey Oak	Tri-View	Rectangle	30	30	4 1/4	CR93079	30	5 1/2	5 1/2
907236	Honey Oak	Tri-View	Rectangle	36	30	4 1/4	CR93679	36	5 1/2	5 1/2
907248	Honey Oak	Tri-View	Rectangle	48	30	4 1/4				
B. Prestique White Surface Mount										
902224	White	Tri-View	Rectangle	24	26	4 1/4				
902230	White	Tri-View	Rectangle	30	30	4 1/4				
902236	White	Tri-View	Rectangle	36	30	4 1/4				
C. Prestique Frameless Surface Mount										
905224	Frameless	Tri-View	Rectangle	24	26	4 1/4	CR92490	24	4 1/2	5 1/2
905230	Frameless	Tri-View	Rectangle	30	30	4 1/4	CR93090	30	4 1/2	5 1/2
905236	Frameless	Tri-View	Rectangle	36	30	4 1/4	CR93690	36	4 1/2	5 1/2
905248	Frameless	Tri-View	Rectangle	48	30	4 1/4	CR94890	48	4 1/2	5 1/2

Note: All measurements are in inches.
 ■ Cabinet depth does NOT include light bulbs or the socket.

Model Number	Frame Finish	Door Type	Mirror Shape	Overall Size			Wall Opening			Top Light Kit
				w	h	d	w	h	d	
Wood Frame with Built-In Top Light Recessed or Surface Mount										
9422BC	White	Single	Rectangle	15 1/16	23 1/2	4 1/4	14 1/4	22 1/2	3 1/2	Built-In
942224	White	Tri-View	Rectangle	23 3/16	28 1/2	4 1/4	22 1/2	27 1/4	3 1/2	Built-In
942230	White	Tri-View	Rectangle	29 3/16	28 1/2	4 1/4	28 1/2	27 1/4	3 1/2	Built-In
942236	White	Tri-View	Rectangle	35 3/16	28 1/2	4 1/4	34 1/2	27 1/4	3 1/2	Built-In
9472	Honey Oak	Single	Rectangle	15 1/16	23 1/2	4 1/4	14 1/4	22 1/2	3 1/2	Built-In
947224	Honey Oak	Tri-View	Rectangle	23 3/16	28 1/2	4 1/4	22 1/2	27 1/4	3 1/2	Built-In
947230	Honey Oak	Tri-View	Rectangle	29 3/16	28 1/2	4 1/4	28 1/2	27 1/4	3 1/2	Built-In
947236	Honey Oak	Tri-View	Rectangle	35 3/16	28 1/2	4 1/4	34 1/2	27 1/4	3 1/2	Built-In

Wood Frame Cabinets Surface Mount										
902	Honey Oak	Single	Rectangle	16	20	4 1/4				
902WH	White	Single	Rectangle	16	20	4 1/4				
962224	White	Tri-View	Rectangle	24	26	4 1/4				
962230	White	Tri-View	Rectangle	30	26	4 1/4				
962236	White	Tri-View	Rectangle	36	26	4 1/4				
967224	Honey Oak	Tri-View	Rectangle	24	26	4 1/4				
967230	Honey Oak	Tri-View	Rectangle	30	26	4 1/4				
967236	Honey Oak	Tri-View	Rectangle	36	26	4 1/4				
982	Honey Oak	Single	Rectangle	16	26	4 1/4				
982WH	White	Single	Rectangle	16	26	4 1/4				

Note: All measurements are in inches.
 ■ Cabinet depth does NOT include light bulbs or the socket.

Louver Door



Hideaway



Drop Door Perfume Cabinet



Perfume Medicine Cabinet



Shown: Louver Door 602



Shown: Louver Door 606

Shown: Hideaway 622 (painted to match wall)



Shown: Drop Door Perfume Cabinet 9877



Shown: Perfume Medicine Cabinet 972225

Our versatile Louver Door cabinets provide additional storage yet are cleverly concealed. The unfinished pine louver door is ready to be painted or stained to match your bath or powder room. Or, choose a white molded polystyrene door (model 615 only) that does not require a finish.

The steel door of the Hideaway can be painted or wallpapered to visually blend with any wall finish. This hidden storage solution can be installed for left- or right-hand door opening, and secures with a magnetic latch.

The Drop Door Perfume Cabinet is an attractive way to display small perfume vessels or other unique collectibles. The drop door features a stenciled pattern panel with a 3/4" bevel, and mirrored upper doors with a matching 3/4" beveled edge. Two adjustable shelves let you customize storage to suit your needs. For an elegant finishing touch, brass hinges, knobs and shelf supports provide just the right complement to your bath or powder room accessories.

Add style and variety to any bath or powder room with a distinctive two-compartment Perfume Medicine Cabinet. The vertical compartment features a clear, beveled-edge glass window with a delicate stenciled pattern. It's perfect for displaying designer fragrances and colorful beauty items on three generous shelves. The large compartment features a framed, beveled-edge mirrored door and two shelves. Brass hardware finishes the cabinet handsomely.

Model Number	Frame Type	Door Type	Mirror Shape	Overall Size			Wall Opening		
				w	h	d	w	h	d
Louver Door Recessed Mount									
602	Unfinished	Single	Arched	16	24	-	14	18	3½
605ADJ*	Unfinished	Single	Arched	16	24	4½	14	18	2½
606	Unfinished	Single	Rectangle	16	22	-	14	18	3½
607ADJ*	Unfinished	Single	Rectangle	16	22	4½	14	18	2½
609	Unfinished	Single	Rectangle	16	26	-	14	24	3½
615*	Polystyrene	Single	Rectangle	16¼	24½	4%	14	18	2½

Hideaway Recessed Mount									
622	Frameless	Single	Rectangle	16¼	21¾	-	14	18	3¼

Note: All measurements are in inches.
* Molded body.

Model Number	Frame Finish	Door Type	Mirror Shape	Overall Size			Wall Opening		
				w	h	d	w	h	d
Drop Door Perfume Cabinet Recessed or Surface Mount									
9873	White	2-Door, Drop	Rectangle	30¼	29¼	4¼	28¼	27¼	3¼
9877	Honey Oak	2-Door, Drop	Rectangle	30¼	29¼	4¼	28¼	27¼	3¼

Perfume Medicine Cabinet Recessed or Surface Mount									
972225	White	2-Door	Rectangle	25¼	28	4¼	24¼	26¼	3¼
977225	Honey Oak	2-Door	Rectangle	25¼	28	4¼	24¼	26¼	3¼

Note: All measurements are in inches.

Model No.	Pg No.	Style Name	Frame	Style ¹	Overall Size w h d	Mount Type ²	Wall Opening w h d	Hinge Type ³	Single Door Hinge ⁴	Cab Bdy ⁵	Shelves Qty, Material ⁷ , Type	Matching Light Fixture	Rec. Bulbs Qty-Type
124LP ⁸	39	Ensign	Stainless Steel Trim	SB	24 23 $\frac{3}{4}$ 8 $\frac{1}{4}$	SM	– – –	–	–	S	1, S, Fixed	Built-In	4-60W Std. MB
128LP ⁸	39	Ensign	Stainless Steel Trim	SB	28 23 $\frac{3}{4}$ 8 $\frac{1}{4}$	SM	– – –	–	–	S	1, S, Fixed	Built-In	4-60W Std. MB
1350 ⁶	14	Cameo Oval Bevel	Frameless Bevel	S	21 31 –	R	14 18 3 $\frac{1}{2}$	P	RV	S	2, P, Adjus.	–	–
1358	14	Cameo Oval Bevel	Frameless Bevel	S	24 36 –	R	14 24 3 $\frac{1}{2}$	P	RV	S	3, S, Adjus.	–	–
1370 ⁶	24	Dunhill	Solid Oak, Honey	S	21 31 5 $\frac{1}{2}$	R	14 18 3 $\frac{1}{2}$	P	RV	S	2, P, Adjus.	–	–
1370M ⁶	24	Dunhill	Solid Maple	S	21 31 5 $\frac{1}{2}$	R	14 18 3 $\frac{1}{2}$	P	RV	S	2, G, Adjus.	–	–
1370WH ⁶	24	Dunhill	White Painted	S	21 31 5 $\frac{1}{2}$	R	14 18 3 $\frac{1}{2}$	P	RV	S	2, G, Adjus.	–	–
1402	17	Lafayette	Frameless	S	18 $\frac{1}{2}$ 32 $\frac{1}{2}$ 4 $\frac{1}{2}$	SM	– – –	P	R	S	3, S, Adjus.	Built-In	3-60W G25/G40
1430	18	Focus	Frameless	S	16 22 4 $\frac{1}{2}$	R	14 18 3 $\frac{1}{2}$	P	RV	S	2, P, Adjus.	–	–
1433	18	Focus	Frameless	S	16 $\frac{1}{2}$ 20 $\frac{1}{2}$ –	R	14 18 2 $\frac{1}{2}$	P	RV	P	2, P, Fixed	–	–
1438	18	Focus	Frameless	S	16 26 –	R	14 24 3 $\frac{1}{2}$	P	RV	S	3, S, Adjus.	–	–
1447	35	Stainless Steel	Frameless	S	16 20 –	R	14 18 3 $\frac{1}{2}$	P	RV	SS	3, G, Adjus.	–	–
1448	35	Stainless Steel	Frameless	S	16 26 –	R	14 24 3 $\frac{1}{2}$	P	RV	SS	3, G, Adjus.	–	–
1450BC	16	Mirror-on-Mirror	Frameless	S	16 26 5	R	14 18 3 $\frac{1}{2}$	P	RV	S	2, P, Adjus.	73290*, 73190**	–
1451	18	Horizon	Frameless	S	16 26 4 $\frac{1}{2}$	R	14 18 3 $\frac{1}{2}$	P	RV	S	2, P, Adjus.	73290*	–
1452	16	Mirror-On-Mirror	Frameless	S	16 26 5	R	14 18 3 $\frac{1}{2}$	P	RV	S	2, P, Adjus.	73290*, 73190**	–
1453	18	Horizon	Frameless	S	16 $\frac{1}{2}$ 20 $\frac{1}{2}$ –	R	14 18 2 $\frac{1}{2}$	P	RV	P	2, P, Fixed	73290*, 73190**	–
1453ADJ	18	Horizon	Frameless	S	16 $\frac{1}{2}$ 20 $\frac{1}{2}$ –	R	14 18 2 $\frac{1}{2}$	P	RV	P	2, P, Adjus.	73290*	–
1454	15	Mirage	Frameless	S	18 27 4 $\frac{1}{2}$	R	14 18 3 $\frac{1}{2}$	P	RV	S	2, P, Adjus.	73190**	–
1456	15	Mirage	Frameless	S	17 $\frac{1}{2}$ 32 –	R	14 24 3 $\frac{1}{2}$	P	RV	S	3, S, Adjus.	73190**	–
1459	18	Horizon	Frameless	S	16 26 4 $\frac{1}{2}$	R	14 24 3 $\frac{1}{2}$	P	RV	S	3, P, Adjus.	73290*, 73190**	–
1462	17	Lafayette	Frameless	S	18 $\frac{1}{2}$ 28 $\frac{1}{2}$ 4 $\frac{1}{2}$	SM	– – –	P	R	S	3, S, Adjus.	Built-In	3-60W G25/G40
155124	19	Vienna	Chrome Finish Trim	T	24 26 5 $\frac{1}{2}$	SM	– – –	L	–	S	2, S, Adjus.	SB22529	–
155130	19	Vienna	Chrome Finish Trim	T	30 26 5 $\frac{1}{2}$	SM	– – –	L	–	S	2, S, Adjus.	SB23129	–
177924 ⁶	27	Oakhill	Solid Oak, Honey	T	23 $\frac{1}{2}$ 29 4 $\frac{1}{2}$	R/SM	22 $\frac{1}{2}$ 27 $\frac{1}{2}$ 3 $\frac{1}{2}$ ⁹	PN	–	S	2, S, Adjus.	Built-In	3-60W G25/G40
177930 ⁶	27	Oakhill	Solid Oak, Honey	T	29 $\frac{1}{2}$ 29 4 $\frac{1}{2}$	R/SM	28 $\frac{1}{2}$ 27 $\frac{1}{2}$ 3 $\frac{1}{2}$ ⁹	PN	–	S	2, S, Adjus.	Built-In	4-60W G25/G40
177936 ⁶	27	Oakhill	Solid Oak, Honey	T	35 $\frac{1}{2}$ 29 4 $\frac{1}{2}$	R/SM	34 $\frac{1}{2}$ 27 $\frac{1}{2}$ 3 $\frac{1}{2}$ ⁹	PN	–	S	2, S, Adjus.	Built-In	5-60W G25/G40
177948 ⁶	27	Oakhill	Solid Oak, Honey	T	47 $\frac{1}{2}$ 29 4 $\frac{1}{2}$	R/SM	46 $\frac{1}{2}$ 27 $\frac{1}{2}$ 3 $\frac{1}{2}$ ⁹	PN	–	S	2, S, Adjus.	Built-In	6-60W G25/G40
2072 ⁶	27	Oakdale	Solid Oak, Honey	S	17 $\frac{1}{2}$ 29 4 $\frac{1}{2}$	R/SM	16 $\frac{1}{2}$ 27 $\frac{1}{2}$ 3 $\frac{1}{2}$ ⁹	PN	R	S	2, S, Adjus.	Built-In	3-60W G25/G40
24711L ⁸	38	Oak Hollywood	Solid Oak, Honey	SB	24 $\frac{1}{2}$ 24 $\frac{1}{2}$ 9	SM	– – –	–	–	S	1, S, Fixed	Built-In	4-60W Std. MB
255024 ⁶	18	Horizon	Frameless	T	24 24 5	R	21 $\frac{1}{2}$ 20 $\frac{1}{2}$ 3 $\frac{1}{2}$	C	–	S	2, S, Adjus.	H042490†	–
255030 ⁶	18	Horizon	Frameless	T	30 28 $\frac{1}{2}$ 5	R	27 $\frac{1}{2}$ 24 $\frac{1}{2}$ 3 $\frac{1}{2}$	C	–	S	2, S, Adjus.	H043090†	–
255036 ⁶	18	Horizon	Frameless	T	36 28 $\frac{1}{2}$ 5	R	33 $\frac{1}{2}$ 24 $\frac{1}{2}$ 3 $\frac{1}{2}$	C	–	S	2, S, Adjus.	H043690†	–
255048 ⁶	18	Horizon	Frameless	T	48 28 $\frac{1}{2}$ 5	R	45 $\frac{1}{2}$ 24 $\frac{1}{2}$ 3 $\frac{1}{2}$	C	–	S	2, S, Adjus.	H044890†	–
255224 ⁶	18	Horizon	Frameless	T	24 24 5 $\frac{1}{2}$	SM	– – –	C	–	S	2, S, Fixed	H032490†	–
255230 ⁶	18	Horizon	Frameless	T	30 28 $\frac{1}{2}$ 5 $\frac{1}{2}$	SM	– – –	C	–	S	2, S, Fixed	H033090†	–
255236 ⁶	18	Horizon	Frameless	T	36 28 $\frac{1}{2}$ 5 $\frac{1}{2}$	SM	– – –	C	–	S	2, S, Fixed	H033690†	–
255248 ⁶	18	Horizon	Frameless	T	48 28 $\frac{1}{2}$ 5 $\frac{1}{2}$	SM	– – –	C	–	S	2, S, Fixed	H034890†	–
258	15	Sonata	Frameless	S	16 32 –	R	14 24 3 $\frac{1}{2}$	P	R	S	3, P, Adjus.	72052	–
277936 ⁶	28	Grand Oak	Solid Oak, Honey	T	35 $\frac{1}{2}$ 29 4 $\frac{1}{2}$	R/SM	34 $\frac{1}{2}$ 27 $\frac{1}{2}$ 3 $\frac{1}{2}$ ⁹	PN	–	S	2, S, Adjus.	–	–
277936M ⁶	28	Grand Maple	Solid Maple	T	35 $\frac{1}{2}$ 29 4 $\frac{1}{2}$	R/SM	34 $\frac{1}{2}$ 27 $\frac{1}{2}$ 3 $\frac{1}{2}$ ⁹	PN	–	S	2, S, Adjus.	–	–

Chart/Notes Key:

- 1. Style**
B = Bi-View
L = Light
S = Single
SB = Slider
T = Tri-View
WM = Wall Mirror
- 2. Mount Type**
M = Mirror
R = Recessed
SM = Surface Mount
R/SM = Recessed or Surface Mount
- 3. Hinge Type**
B = Butt
C = Concealed
L = Leaf
P = Piano
PN = Pin
SC = Semi-concealed, self-closing hinge
- 4. Single Door Hinge**
L = Left
R = Right
RV = Reversible
- 5. Cabinet Body**
AL = Aluminum
G = Glass
P = Polystyrene
S = Steel
SS = Stainless
W = Wood
- Cabinet bottom always provides an additional storage level.
- 7. Shelf Material**
AL = Aluminum
G = Glass
P = Polystyrene
S = Steel
W = Wood
- Door(s) shipped not attached to cabinet
- Optional wall opening
* Top light kit, see photo page 16.
** Side light kit, see photo page 16.
† Top light kit, see page 18.

NOTES: Unless so stated, bulbs not included. All measurements are in inches.

Model No.	Pg No.	Style Name	Frame	Style ¹	Overall Size w h d	Mount Type ²	Wall Opening w h d	Hinge Type ³	Single Door Hinge ⁴	Cab Bdy ⁵	Shelves Qty, Material ⁷ , Type	Matching Light Fixture	Rec. Bulbs Qty-Type
277948 ⁶	28	Grand Oak	Solid Oak, Honey	T	47 $\frac{1}{2}$ 29 4 $\frac{1}{2}$	R/SM	46 $\frac{1}{2}$ 27 $\frac{1}{2}$ 3 $\frac{1}{2}$ ⁹	PN	–	S	2, S, Adjus.	–	–
28711L ⁸	38	Oak Hollywood	Solid Oak, Honey	SB	28 $\frac{1}{2}$ 24 $\frac{1}{2}$ 9	SM	– – –	–	–	S	1, S, Fixed	Built-In	4-60W Std. MB
295224	18	Focus	Frameless	T	24 30 5 $\frac{1}{2}$	SM	– – –	C	–	S	2, S, Fixed	Built-In	3-60W G25/G40
295230	18	Focus	Frameless	T	30 34 5 $\frac{1}{2}$	SM	– – –	C	–	S	2, S, Fixed	Built-In	4-60W G25/G40
323LP ⁶	39	Flair	Stainless Steel Trim	SB	24 19 $\frac{1}{2}$ 7 $\frac{1}{2}$	SM	– – –	–	–	S	1, S, Fixed	Built-In	4-60W Std. MB
327LP ⁶	39	Flair	Stainless Steel Trim	SB	28 19 $\frac{1}{2}$ 7 $\frac{1}{2}$	SM	– – –	–	–	S	1, S, Fixed	Built-In	4-60W Std. MB
401ADJ ⁶	40	Styleline	Stainless Steel	S	16 20 3 $\frac{1}{4}$	R	14 18 2 $\frac{1}{2}$	B	RV	P	2, P, Adjus.	–	–
405BP [■]	40	Styleline	Stainless Steel	S	16 22 –	R	14 18 3	B	RV	P	2, P, Adjus.	–	–
407ADJ ⁶	40	Styleline	Stainless Steel	S	16 22 3 $\frac{1}{4}$	R	14 18 2 $\frac{1}{2}$	B	RV	P	2, P, Adjus.	–	–
420BC	40	Styleline	Stainless Steel	S	16 22 –	R	14 20 3 $\frac{1}{2}$	P	RV	S	3, S, Adjus.	–	–
421BC	40	Styleline	Stainless Steel	S	16 22 –	R	14 20 3 $\frac{1}{2}$	P	RV	S	3, S, Adjus.	–	–
422SM	40	Styleline	Stainless Steel	S	14 20 5 $\frac{1}{2}$	SM	– – –	P	RV	S	2, P, Fixed	–	–
449BC	40	Styleline	Stainless Steel	S	16 22 –	R	14 18 2 $\frac{1}{2}$	P	RV	P	2, P, Fixed	–	–
452SM	40	Styleline	Stainless Steel	S	16 22 5 $\frac{1}{2}$	SM	– – –	P	RV	S	2, P, Fixed	–	–
455FL	36	Cabinet 455FL	Stainless Steel	S	20 $\frac{1}{2}$ 22 $\frac{1}{2}$ 3 $\frac{1}{4}$	R	14 19 3 $\frac{1}{2}$	P	R	S	2, P, Adjus.	Built-In	Fluor. (incl.)
455230 ⁶	19	Quantum	Frameless	T	30 36 $\frac{1}{2}$ 5 $\frac{1}{2}$	SM	– – –	C	–	S	2, S, Fixed	Built-In	4-60W G25/G40
455236 ⁶	19	Quantum	Frameless	T	36 36 $\frac{1}{2}$ 5 $\frac{1}{2}$	SM	– – –	C	–	S	2, S, Fixed	Built-In	5-60W G25/G40
455248 ⁶	19	Quantum	Frameless	T	48 36 $\frac{1}{2}$ 5 $\frac{1}{2}$	SM	– – –	C	–	S	2, S, Fixed	Built-In	6-60W G25/G40
458	40	Styleline	Stainless Steel	S	16 26 –	R	14 24 3 $\frac{1}{2}$	P	RV	S	3, S, Adjus.	–	–
468BC	40	Styleline	Stainless Steel	S	16 26 –	R	14 24 3 $\frac{1}{2}$	P	RV	S	3, S, Adjus.	–	–
468MOD	34	Modular Shelf	Stainless Steel	S	16 26 –	R	14 24 3 $\frac{1}{2}$	P	RV	S	6**, S, Adjus.	–	–
470FS*	40	Styleline	Stainless Steel	S	16 26 5 $\frac{1}{2}$	R	14 24 3 $\frac{1}{2}$	P	RV	S	3, G, Adjus.	–	–
472FS*	40	Styleline	Stainless Steel	S	16 22 –	SM	– – –	P	RV	S	3, G, Adjus.	–	–
473FS*	40	Styleline	Stainless Steel	S	16 22 –	R	14 18 3 $\frac{1}{2}$	P	RV	S	3, G, Adjus.	–	–
478FS*	40	Styleline	Stainless Steel	S	16 26 5 $\frac{1}{2}$	R	14 24 3 $\frac{1}{2}$	P	RV	S	3, A, Adjus.	–	–
490	40	Styleline	Stainless Steel	S	18 24 –	R	16 21 $\frac{1}{2}$ 3 $\frac{1}{2}$	P	RV	S	3, P, Adjus.	–	–
495	40	Styleline	Stainless Steel	S	20 30 –	R	17 $\frac{1}{2}$ 26 $\frac{1}{2}$ 3 $\frac{1}{2}$	P	RV	S	3, P, Adjus.	–	–
52WH184PV ⁶	11	Metro Oval	Frameless, Bevel	S	21 $\frac{1}{2}$ 31 $\frac{1}{2}$ 4 $\frac{1}{2}$	R	14 $\frac{1}{2}$ 18 3 $\frac{1}{2}$	P	RV	S	2, G, Adjus.	–	–
52WH244DP ⁶	7	Metro Deluxe	Frameless, Bevel	S	15 25 5	R/SM†	14 $\frac{1}{2}$ 24 4	C	RV	S	4, G, Adjus.	–	–
52WH244DPF ⁶	7	Metro Deluxe	Frameless, Flat	S	15 25 5	R/SM†	14 $\frac{1}{2}$ 24 4	C	RV	S	4, G, Adjus.	–	–
52WH244P ⁶	9	Metro Classic	Frameless, Bevel	S	15 25 5	R/SM†	14 $\frac{1}{2}$ 24 4	C	RV	S	3, G, Adjus.	–	–
52WH244PA ⁶	11	Metro Arch	Frameless, Bevel	S	15 31 $\frac{1}{2}$ 5	R/SM†	14 $\frac{1}{2}$ 24 4	C	R	S	3, G, Adjus.	–	–

Model No.	Pg No.	Style Name	Frame	Style ¹	Overall Size w h d	Mount Type ²	Wall Opening w h d	Hinge Type ³	Single Door Hinge ⁴	Cab Bdy ⁵	Shelves Qty ⁶ , Material ⁷ , Type	Matching Light Fixture	Rec. Bulbs Qty-Type
52WH304PF ⁸	13	Metro Oversize Classic	Frameless, Flat	S	24 30 5	R/SM [†]	23 29 4	C	RV	S	4, G, Adjus.	-	-
52WH344DP ⁸	7	Metro Deluxe	Frameless, Bevel	S	15 35 5	R/SM [†]	14 34 4	C	RV	S	5, G, Adjus.	-	-
52WH344DPF ⁸	7	Metro Deluxe	Frameless, Flat	S	15 35 5	R/SM [†]	14 34 4	C	RV	S	5, G, Adjus.	-	-
52WH344P ⁸	9	Metro Classic	Frameless, Bevel	S	15 35 5	R/SM [†]	14 34 4	C	RV	S	4, G, Adjus.	-	-
52WH344PF ⁸	9	Metro Classic	Frameless, Flat	S	15 35 5	R/SM [†]	14 34 4	C	RV	S	4, G, Adjus.	-	-
52WH346DP ⁸	7	Metro Deluxe	Frameless, Bevel	S	15 35 7	R	14 34 6	C	RV	S	5, G, Adjus.	-	-
52WH346DPF ⁸	7	Metro Deluxe	Frameless, Flat	S	15 35 7	R	14 34 6	C	RV	S	5, G, Adjus.	-	-
530924	16	Simplicity	Frameless	S	24 30 4 1/2	R	21 27 3 1/2	P	RV	S	2, G, Adjus.	-	-
533124	30	Harmony	Chrome-Tone	S	24 30 5 1/2	R	21 27 3 1/2	P	RV	S	2, G, Adjus.	-	-
535224	31	Monaco	Gold-Tone	S	24 30 5 1/2	R	21 27 3 1/2	P	RV	S	2, G, Adjus.	-	-
5528	14	Torino	Frameless	S	16 3/4 34 1/2 4 1/2	R	14 24 3 1/2	P	R	S	3, P, Adjus.	73591	-
5551L	36	Cabinet 5551L	Stainless Steel	S	16 24 8	SM	- - -	P	R	S	2, P, Fixed	Built-In	2-60W
565	17	Styleline II	Chrome Plated Steel	S	18 28 4 1/2	SM	- - -	P	R	S	3, S, Adjus.	Built-In	3-60W G25/G40
602	44	Louver Door	Unfinished Pine	S	16 24 -	R	14 18 3 1/2	B	R	S	2, P, Adjus.	-	-
605ADJ	44	Louver Door	Unfinished Pine	S	16 24 4 1/2	R	14 18 2 1/2	B	R	P	2, P, Adjus.	-	-
606	44	Louver Door	Unfinished Pine	S	16 22 -	R	14 18 3 1/2	B	RV	S	2, P, Adjus.	-	-
607ADJ	44	Louver Door	Unfinished Pine	S	16 22 4 1/2	R	14 18 2 1/2	B	RV	P	2, P, Adjus.	-	-
609	44	Louver Door	Unfinished Pine	S	16 26 -	R	14 24 3 1/2	P	RV	S	3, S, Adjus.	-	-
610BC	18	Horizon	Frameless	S	16 1/2 22 1/2 3 1/2	R	14 18 2 1/2	B	RV	P	2, P, Fixed	73290*, 73190**	-
614	40	Styleline	Stainless Steel	S	16 1/2 22 1/2 4 1/2	SM	- - -	B	RV	P	2, P, Fixed	-	-
615	44	Louver Door	White Polystyrene	S	16 1/2 24 1/2 4 1/2	R	14 18 2 1/2	B	R	P	2, P, Fixed	-	-
622	44	Hideaway	Steel Door	S	16 1/2 21 1/2 -	R	14 18 3 1/2	P	RV	S	2, P, Adjus.	-	-
624	40	Styleline	Stainless Steel	S	16 26 -	R	13 23 2 1/2	B	RV	P	3, P, Fixed	-	-
625	35	Bel Aire Auxiliary	Stainless Steel Trim	S	13 36 -	R	11 1/2 33 1/2 3 1/2	P	RV	S	3, P, Adjus.	-	-
626	35	Bel Aire Auxiliary	Stainless Steel Trim	S	13 36 4 1/2	SM	- - -	P	RV	S	3, P, Fixed	-	-
629	32	Illusion	Frameless	S	15 36 3 1/2	R	14 34 3 1/2	C	RV	S	3, S, Adjus.	-	-
629SS	32	Illusion	Frameless	S	15 36 3 1/2	R	14 34 3 1/2	C	RV	SS	4, G, Adjus.	-	-
631	33	Avanti Corner	Stainless Steel Trim	S	13 36 7 1/2	SM	- - -	P	RV	S	3, G, Fixed	-	-
637	33	Avanti Corner	Frameless	S	11 1/2 36 8	SM	- - -	P	RV	P	3, P, Fixed	-	-
639BC	32	Illusion	Frameless	S	13 36 -	R	12 34 3 1/2	C	RV	S	3, S, Adjus.	-	-
663BC	33	Low Profile	Frameless	S	15 36 3 1/2	R	12 34 3 1/2	P	RV	S	3, G, Adjus.	-	-
664	32	Illusion	Frameless	S	13 36 -	R	12 34 3 1/2	C	RV	S	3, G, Adjus.	-	-
669730	41	Frameless Tri-View	Frameless	T	30 24 5	SM	- - -	L	-	P	4, P, Adjus.	-	-
672BC ⁸	34	Centered Corner	Solid Oak, Honey	S	19 1/2 33 1/2 10 1/2	SM	- - -	PN	R	S	3, S, Fixed	-	-
672SS ⁸	34	Centered Corner	Stainless Steel	S	17 1/2 31 9 1/2	SM	- - -	PN	R	S	3, S, Fixed	-	-
70223	21	Baker Street	Hardwood, White	L	18 8 13 1/2	For SM Cab	- - -	-	-	-	-	-	2-60W Std. MB
70273	21	Baker Street	Solid Oak, Honey	L	18 8 13 1/2	For SM Cab	- - -	-	-	-	-	-	2-60W Std. MB
70323	21	Baker Street	Hardwood, White	L	18 8 9	For R Cab	- - -	-	-	-	-	-	2-60W Std. MB
70324	21	Baker Street	Solid Maple	L	18 8 9	For R Cab	- - -	-	-	-	-	-	2-60W Std. MB
70373	21	Baker Street	Solid Oak, Honey	L	18 8 9	For R Cab	- - -	-	-	-	-	-	2-60W Std. MB
70928	25	Prairie	White Painted Wood	L	17 1/2 8 8	For R Cab	- - -	-	-	-	-	-	2-60W Std. MB

Chart/Notes Key:

- 1. Style**
B = Bi-View
L = Light
S = Single
SB = Slider
T = Tri-View
WM = Wall Mirror
- 2. Mount Type**
M = Mirror
R = Recessed
SM = Surface Mount
R/SM = Recessed or Surface Mount
- 3. Hinge Type**
B = Butt
C = Concealed
L = Leaf
P = Piano
PN = Pin
SC = Semi-concealed, self-closing hinge
- 4. Single Door Hinge**
L = Left
R = Right
RV = Reversible
- 5. Cabinet Body**
AL = Aluminum
G = Glass
P = Polystyrene
S = Steel
SS = Stainless
W = Wood
- 6.** Cabinet bottom always provides an additional storage level.
- 7. Shelf Material**
AL = Aluminum
G = Glass
P = Polystyrene
S = Steel
W = Wood
- 8.** Door(s) shipped not attached to cabinet
* Top light kit, see photo page 16.
** Side light kit, see photo page 16.
† Surface Mount Side Mirror Kits required

NOTES: Unless so stated, bulbs not included. All measurements are in inches.

Model No.	Pg No.	Style Name	Frame	Style ¹	Overall Size w h d	Mount Type ²	Wall Opening w h d	Hinge Type ³	Single Door Hinge ⁴	Cab Bdy ⁵	Shelves Qty ⁶ , Material ⁷ , Type	Matching Light Fixture	Rec. Bulbs Qty-Type
71829	29	Kingston	Solid Oak, Honey	L	16 1/2 5 1/2 2 1/2	For R Cab	- - -	-	-	-	-	-	3-60W G25/G40
72052	15	Sonata	Frameless	L**	5 17 6 1/2	For R Cab	- - -	-	-	-	-	-	2-60W Std. MB
73190	15, 16, 18	Mirage	Frameless	L**	5 12 6 1/2	For R Cab	- - -	-	-	-	-	-	2-60W Slim Line
73290	16, 18	Horizon	Frameless	L	16 4 1/2 2	For R Cab	- - -	-	-	-	-	-	2-60W G25/G40
73591	14	Torino	Frameless	L**	6 1/2 13 1/2 5 1/2	For R Cab	- - -	-	-	-	-	-	2-60W Std. MB
74279	25	Grant	Solid Oak, Honey	L	16 1/2 5 1/2 3	For R Cab	- - -	-	-	-	-	-	2-60W G25/G40
76GK ¹⁰	7, 9	Metro	-	-	for both 24" and 34" models	- - -	-	-	-	-	-	-	Gangable Attachment Kit
760024	7, 9	Metro	Frameless	-	for models 24" in height	- - -	-	-	-	-	-	-	Surface Mount Mirror Kit
760025	13	Metro Oversize	Frameless	-	for models 25" in height	- - -	-	-	-	-	-	-	Surface Mount Mirror Kit
760030	13	Metro Oversize	Frameless	-	for models 30" in height	- - -	-	-	-	-	-	-	Surface Mount Mirror Kit
760034	7, 9	Metro	Frameless	-	for models 34" in height	- - -	-	-	-	-	-	-	Surface Mount Mirror Kit
76378	26	Canterbury	Solid Oak, Honey	L	18 8 8	For R Cab	- - -	-	-	-	-	-	2-60W Std. MB
76478	26	Canterbury	Solid Oak, Honey	L	18 8 11 1/2	For SM Cab	- - -	-	-	-	-	-	2-60W Std. MB
8120	25	Prairie	White Painted Wood	S	17 1/2 27 1/2 -	R	14 18 3 1/2	P	RV	S	2, P, Adjus.	70928	-
8122	25	Prairie	White Painted Wood	S	17 1/2 27 1/2 -	SM	- - -	P	RV	S	3, P, Fixed	-	-
8128	25	Prairie	White Painted Wood	S	17 1/2 27 1/2 -	R	14 24 3 1/2	P	RV	S	3, P, Adjus.	70928	-
820	21	Baker Street	Hardwood, White	S	18 27 1/2 -	R	14 18 3 1/2	P	RV	S	2, G, Adjus.	70323	-
822	21	Baker Street	Hardwood, White	S	18 27 1/2 5	SM	- - -	P	RV	S	3, G, Adjus.	70223	-
824BC	21	Baker Street	Solid Maple	S	18 27 1/2 -	R	14 24 3 1/2	P	RV	S	3, G, Adjus.	70324	-
8278	26	Chapel Hill	Solid Oak, Honey	S	17 1/2 27 1/2 -	R	14 24 3 1/2	P	RV	S	3, S, Adjus.	-	-
828	21	Baker Street	Hardwood, White	S	18 27 1/2 -	R	14 24 3 1/2	P	RV	S	3, G, Adjus.	70323	-
830C	21	Baker Street Arch	Solid Cherry	S	17 1/2 33 1/2 -	R	14 24 3 1/2	P	R	S	3, G, Adjus.	-	-
8378	29	Kingston	Solid Oak, Honey	S	16 1/2 26 1/2 -	R	14 24 3 1/2	P	RV	S	3, S, Adjus.	71829	-
842230	21	Baker Street	Hardwood, White	T	30 28 1/2 5 1/2	SM	- - -	L	-	S	2, G, Adjus.	BS84023	-
842236	21	Baker Street	Hardwood, White	T	36 28 1/2 5 1/2	SM	- - -	L	-	S	2, G, Adjus.	BS84623	-
850C	23	Soho	Solid Cherry	S	17 1/2 27 1/2 -	R	14 24 3 1/2	P	RV	S	3, G, Adjus.	-	-
850M	23	Soho	Solid Maple	S	17 1/2 27 1/2 -	R	14 24 3 1/2	P	RV	S	3, G, Adjus.	-	-
8570	26	Canterbury	Solid Oak, Honey	S	18 27 1/2 -	R	14 18 3 1/2	P	R	S	2, P, Adjus.	76378	-
8572	26	Canterbury	Solid Oak, Honey	S	18 27 1/2 -	SM	- - -	P	R	S	3, P, Fixed	76478	-
870	21	Baker Street	Solid Oak, Honey	S	18 27 1/2 -	R	14 18 3 1/2	P	RV	S	2, G, Adjus.	70373	-
872BC	21	Baker Street	Solid Oak, Honey	S	18 27 1/2 5	SM	- - -	P	RV	S	3, G, Adjus.	70273	-
8770	25	Grant	Solid Oak, Honey	S	16 1/2 24 1/2 -	R	14 18 3 1/2	P	RV	S	2, P, Adjus.	74279	-
8772	25	Grant	Solid Oak, Honey	S	16 1/2 24 1/2 5 1/2	SM	- - -	P	RV	S	2, P, Fixed	-	-
8773	25	Grant	Solid Oak, Honey	S	16 1/2 22 -	R	14 18 2 1/2	B	RV	P	2, P, Fixed	74279	-
8778	25	Grant	Solid Oak, Honey	S	16 1/2 26 1/2 -	R	14 24 3 1/2	P	RV	S	3, P, Adjus.	74279	-
878BC	21	Baker Street	Solid Oak, Honey	S	18 27 1/2 -	R	14 24 3 1/2	P	RV	S	3, G, Adjus.	70373	-
9000C	22	Mission	Solid Cherry	S	17 1/2 33 1/2 5 1/2	R	14 24 3 1/2	P	R	S	3, G, Adjus.	-	-
902	43	Wood Frame	Oak Finish	S	16 20 4 1/2	SM	- - -	B	RV	W	1, W, Fixed	-	-
902WH	43	Wood Frame	White Finish	S	16 20 4 1/2	SM	- - -	B	RV	W	1, W, Fixed	-	-

Chart/Notes Key:

- 1. Style**
B = Bi-View
L = Light
S = Single
SB = Slider
T = Tri-View
WM = Wall Mirror
- 2. Mount Type**
M = Mirror
R = Recessed
SM = Surface Mount
R/SM = Recessed or Surface Mount
- 3. Hinge Type**
B = Butt
C = Concealed
L = Leaf
P = Piano
PN = Pin
SC = Semi-concealed, self-closing hinge
- 4. Single Door Hinge**
L = Left
R = Right
RV = Reversible
- 5. Cabinet Body**
AL = Aluminum
G = Glass
P = Polystyrene
S = Steel
SS = Stainless
W = Wood
- 6.** Cabinet bottom always provides an additional storage level.
- 7. Shelf Material**
AL = Aluminum
G = Glass
P = Polystyrene
S = Steel
W = Wood
- 10.** To determine the quantity of Gang Kits needed, subtract 1 from the number of cabinets to be "ganged."
Example 1: Recess three cabinets in a row (3 cabinets - 1) = 2 Gangable Attachment Kits.
Example 2: Surface mount four cabinets in a row (4 cabinets - 1) = 3 Gangable Attachment Kits, plus four Surface Mount Side Mirror Kits.

NOTES: Unless so stated, bulbs not included. All measurements are in inches.
* Special Order ** Packed in pairs

Model No.	Pg No.	Style Name	Frame	Style ¹	Overall Size w h d	Mount Type ²	Wall Opening w h d	Hinge Type ³	Single Door Hinge ⁴	Cab Bdy ⁵	Shelves Qty, Material ⁷ , Type	Matching Light Fixture	Rec. Bulbs Qty-Type
902224	42	Prestique	White Painted Wood	T	24 26 4%	SM	- - -	L	-	W	2, W, Fixed	-	-
902230	42	Prestique	White Painted Wood	T	30 30 4%	SM	- - -	L	-	W	2, W, Fixed	-	-
902236	42	Prestique	White Painted Wood	T	36 30 4%	SM	- - -	L	-	W	2, W, Fixed	-	-
905224 ⁸	42	Prestique	Frameless	T	24 26 4%	SM	- - -	C	-	W	2, W, Fixed	CR92490	-
905230 ⁸	42	Prestique	Frameless	T	30 30 4%	SM	- - -	C	-	W	2, W, Fixed	CR93090	-
905236 ⁸	42	Prestique	Frameless	T	36 30 4%	SM	- - -	C	-	W	2, W, Fixed	CR93690	-
905248 ⁸	42	Prestique	Frameless	T	48 30 4%	SM	- - -	C	-	W	2, W, Fixed	CR94890	-
907224	42	Prestique	Solid Oak, Honey	T	24 26 4%	SM	- - -	L	-	W	2, W, Fixed	-	-
907230	42	Prestique	Solid Oak, Honey	T	30 30 4%	SM	- - -	L	-	W	2, W, Fixed	CR93079	-
907236	42	Prestique	Solid Oak, Honey	T	36 30 4%	SM	- - -	L	-	W	2, W, Fixed	CR93679	-
907248	42	Prestique	Solid Oak, Honey	T	48 30 4%	SM	- - -	L	-	W	2, W, Fixed	-	-
9422BC ⁸	43	Wood Frame w/ light	White Finish	S	15 1/2% 23 1/2% 4%	R/SM	14% 22% 3 1/2%	PN	R	W	1, W, Adjus.	Built-In	2-60W G25/G40
942224 ⁸	43	Wood Frame w/ light	White Finish	T	23% 28% 4%	R/SM	22% 27% 3 1/2%	PN	-	W	2, W, Adjus.	Built-In	3-60W G25/G40
942230 ⁸	43	Wood Frame w/ light	White Finish	T	29% 28% 4%	R/SM	28% 27% 3 1/2%	PN	-	W	2, W, Adjus.	Built-In	4-60W G25/G40
942236 ⁸	43	Wood Frame w/ light	White Finish	T	35% 28% 4%	R/SM	34% 27% 3 1/2%	PN	-	W	2, W, Adjus.	Built-In	5-60W G25/G40
9472 ⁸	43	Wood Frame w/ light	Oak Finish	S	15 1/2% 23 1/2% 4%	R/SM	14% 22% 3 1/2%	PN	R	W	1, W, Adjus.	Built-In	2-60W G25/G40
947224 ⁸	43	Wood Frame w/ light	Oak Finish	T	23% 28% 4%	R/SM	22% 27% 3 1/2%	PN	-	W	2, W, Adjus.	Built-In	3-60W G25/G40
947230 ⁸	43	Wood Frame w/ light	Oak Finish	T	29% 28% 4%	R/SM	28% 27% 3 1/2%	PN	-	W	2, W, Adjus.	Built-In	4-60W G25/G40
947236 ⁸	43	Wood Frame w/ light	Oak Finish	T	35% 28% 4%	R/SM	34% 27% 3 1/2%	PN	-	W	2, W, Adjus.	Built-In	5-60W G25/G40
962224	43	Wood Frame	White Finish	T	24 26 4%	SM	- - -	L	-	W	2, W, Fixed	-	-
962230	43	Wood Frame	White Finish	T	30 26 4%	SM	- - -	L	-	W	2, W, Fixed	-	-
962236	43	Wood Frame	White Finish	T	36 26 4%	SM	- - -	L	-	W	2, W, Fixed	-	-
967224	43	Wood Frame	Oak Finish	T	24 26 4%	SM	- - -	L	-	W	2, W, Fixed	-	-
967230	43	Wood Frame	Oak Finish	T	30 26 4%	SM	- - -	L	-	W	2, W, Fixed	-	-
967236	43	Wood Frame	Oak Finish	T	36 26 4%	SM	- - -	L	-	W	2, W, Fixed	-	-
972225	45	Perfume	White Finish	2-Dr	25 1/2 28 4%	R/SM	24% 26% 3 1/2%	SC	RV	W	5, W, Fixed	-	-
973BC	25	Grant	Solid Oak, Honey	S	16 20 -	R	14 18 2%	B	RV	P	2, P, Fixed	74279	-
977225	45	Perfume	Oak Finish	2-Dr	25 1/2 28 4%	R/SM	24% 26% 3 1/2%	SC	RV	W	5, W, Fixed	-	-
982	43	Wood Frame	Oak Finish	S	16 26 4%	SM	- - -	B	RV	W	2, W, Fixed	-	-
982WH	43	Wood Frame	White Finish	S	16 26 4%	SM	- - -	B	RV	W	2, W, Fixed	-	-
9873	45	Drop Door	White Finish	B	30% 29% 4%	R/SM	28% 27% 3 1/2%	SC	-	W	4, W, F/A	-	-
9877	45	Drop Door	Oak Finish	B	30% 29% 4%	R/SM	28% 27% 3 1/2%	SC	-	W	4, W, F/A	-	-
BS84023	21	Baker Street	Hardwood, White	L	30 6 6%	For SM Cab	- - -	-	-	-	-	-	3-60W Std. MB
BS84623	21	Baker Street	Hardwood, White	L	36 6 6%	For SM Cab	- - -	-	-	-	-	-	4-60W Std. MB
CR92490	42	Prestique	Frameless	L	24 4 1/2 5 1/2	For SM Cab	- - -	-	-	-	-	-	3-60W G25/G40
CR93079	42	Prestique	Solid Oak, Honey	L	30 5 1/2 5 1/2	For SM Cab	- - -	-	-	-	-	-	4-60W G25/G40
CR93090	42	Prestique	Frameless	L	30 4 1/2 5 1/2	For SM Cab	- - -	-	-	-	-	-	4-60W G25/G40

Chart/Notes Key:

- | | | | | | | | | |
|--|--|---|---|--|---|--|--|---|
| 1. Style
B = Bi-View
L = Light
S = Single
SB = Slider
T = Tri-View
WM = Wall Mirror | 2. Mount Type
M = Mirror
R = Recessed
SM = Surface Mount
R/SM = Recessed or Surface Mount | 3. Hinge Type
B = Butt
C = Concealed
L = Leaf
P = Piano
PN = Pin
SC = Semi-concealed, self-closing hinge | 4. Single Door Hinge
L = Left
R = Right
RV = Reversible | 5. Cabinet Body
AL = Aluminum
G = Glass
P = Polystyrene
S = Steel
SS = Stainless
W = Wood | 6. Cabinet bottom always provides an additional storage level. | 7. Shelf Material
AL = Aluminum
G = Glass
P = Polystyrene
S = Steel
SS = Stainless
W = Wood | 8. Door(s) shipped not attached to cabinet
9. Optional wall opening | NOTES: Unless so stated, bulbs not included. All measurements are in inches. |
|--|--|---|---|--|---|--|--|---|

Model No.	Pg No.	Style Name	Frame	Style ¹	Overall Size w h d	Mount Type ²	Wall Opening w h d	Hinge Type ³	Single Door Hinge ⁴	Cab Bdy ⁵	Shelves Qty, Material ⁷ , Type	Matching Light Fixture	Rec. Bulbs Qty-Type
CR93679	42	Prestique	Solid Oak, Honey	L	36 5 1/2 5 1/2	For SM Cab	- - -	-	-	-	-	-	5-60W G25/G40
CR93690	42	Prestique	Frameless	L	36 4 1/2 5 1/2	For SM Cab	- - -	-	-	-	-	-	4-60W G25/G40
CR94890	42	Prestique	Frameless	L	48 4 1/2 5 1/2	For SM Cab	- - -	-	-	-	-	-	5-60W G25/G40
HO32490	18	Horizon	Frameless	L	24 4 1/2 5 1/2	For SM Cab	- - -	-	-	-	-	-	3-60W G25/G40
HO33090	18	Horizon	Frameless	L	30 4 1/2 5 1/2	For SM Cab	- - -	-	-	-	-	-	4-60W G25/G40
HO33690	18	Horizon	Frameless	L	36 4 1/2 5 1/2	For SM Cab	- - -	-	-	-	-	-	4-60W G25/G40
HO34890	18	Horizon	Frameless	L	48 4 1/2 5 1/2	For SM Cab	- - -	-	-	-	-	-	5-60W G25/G40
HO42490	18	Horizon	Frameless	L	24 4 1/2 2 1/2	For R Cab	- - -	-	-	-	-	-	3-60W G25/G40
HO43090	18	Horizon	Frameless	L	30 4 1/2 2 1/2	For R Cab	- - -	-	-	-	-	-	4-60W G25/G40
HO43690	18	Horizon	Frameless	L	36 4 1/2 2 1/2	For R Cab	- - -	-	-	-	-	-	4-60W G25/G40
HO44890	18	Horizon	Frameless	L	48 4 1/2 2 1/2	For R Cab	- - -	-	-	-	-	-	5-60W G25/G40
IL24	37	Commodore	Stainless Steel Trim	L	24 4 7 1/2	For SM Cab	- - -	-	-	-	-	-	4-60W MB
IL30	37	Commodore	Stainless Steel Trim	L	30 4 7 1/2	For SM Cab	- - -	-	-	-	-	-	4-60W MB
PEM2424	37	Commodore	Frameless	WM	24 24 -	SM	- - -	-	-	-	-	IL24	-
PEM3024	37	Commodore	Frameless	WM	30 24 -	SM	- - -	-	-	-	-	IL30	-
PEM3036	37	Commodore	Frameless	WM	30 36 -	SM	- - -	-	-	-	-	IL30	-
PEM3624	37	Commodore	Frameless	WM	36 24 -	SM	- - -	-	-	-	-	-	-
PEM3636	37	Commodore	Frameless	WM	36 36 -	SM	- - -	-	-	-	-	-	-
PEM4824	37	Commodore	Frameless	WM	48 24 -	SM	- - -	-	-	-	-	-	-
PEM4836	37	Commodore	Frameless	WM	48 36 -	SM	- - -	-	-	-	-	-	-
PEM6036	37	Commodore	Frameless	WM	60 36 -	SM	- - -	-	-	-	-	-	-
SB22529	19	Vienna	Chrome Trim	L	24 4 5 1/2	For SM Cab	- - -	-	-	-	-	-	3-60W G25/G40
SB23129	19	Vienna	Chrome Trim	L	30 4 5 1/2	For SM Cab	- - -	-	-	-	-	-	4-60W G25/G40
SB330 ⁸	38	Beauty Glide	Stainless Steel Trim	SB	31 1/2 21 1/2 5 1/4	R	30% 19% 3 1/2	-	-	S	2, G, Adjus.	-	-
V24 ⁸	37	Commodore	Stainless Steel Trim	SB	24% 8% 4%	SM	- - -	-	-	-	-	-	Cosmetic Box, Mirrored Door
V30 ⁸	37	Commodore	Stainless Steel Trim	SB	30% 8% 4%	SM	- - -	-	-	-	-	-	Cosmetic Box, Mirrored Door
V36 ⁸	37	Commodore	Stainless Steel Trim	SB	36% 8% 4%	SM	- - -	-	-	-	-	-	Cosmetic Box, Mirrored Door
V48 ⁸	37	Commodore	Stainless Steel Trim	SB	48% 8% 4%	SM	- - -	-	-	-	-	-	Cosmetic Box, Mirrored Door
VM224M ⁸	37	Commodore	Stainless Steel Trim	SB	24% 32 4%	SM	- - -	-	-	-	-	-	Cosmetic Box & Mirror, Mirrored Door
VM224P ⁸	37	Commodore	Stainless Steel Trim	SB	24% 32 4%	SM	- - -	-	-	-	-	-	Cosmetic Box & Mirror, Styrene Door
VM230M ⁸	37	Commodore	Stainless Steel Trim	SB	30% 32 4%	SM	- - -	-	-	-	-	-	Cosmetic Box & Mirror, Mirrored Door
VM230P ⁸	37	Commodore	Stainless Steel Trim	SB	30% 32 4%	SM	- - -	-	-	-	-	-	Cosmetic Box & Mirror, Styrene Door
VM236M ⁸	37	Commodore	Stainless Steel Trim	SB	36% 32 4%	SM	- - -	-	-	-	-	-	Cosmetic Box & Mirror, Mirrored Door
VM236P ⁸	37	Commodore	Stainless Steel Trim	SB	36% 32 4%	SM	- - -	-	-	-	-	-	Cosmetic Box & Mirror, Styrene Door

Chart/Notes Key:

- | | | | | | | | | |
|--|--|---|---|--|---|--|---|---|
| 1. Style
B = Bi-View
L = Light
S = Single
SB = Slider
T = Tri-View
WM = Wall Mirror | 2. Mount Type
M = Mirror
R = Recessed
SM = Surface Mount
R/SM = Recessed or Surface Mount | 3. Hinge Type
B = Butt
C = Concealed
L = Leaf
P = Piano
PN = Pin
SC = Semi-concealed, self-closing hinge | 4. Single Door Hinge
L = Left
R = Right
RV = Reversible | 5. Cabinet Body
P = Polystyrene
S = Steel
SS = Stainless
W = Wood | 6. Cabinet bottom always provides an additional storage level. | 7. Shelf Material
AL = Aluminum
G = Glass
P = Polystyrene
S = Steel
SS = Stainless
W = Wood | 8. Door(s) shipped not attached to cabinet
* Special Order | NOTES: Unless so stated, bulbs not included. All measurements are in inches. |
|--|--|---|---|--|---|--|---|---|

