

**We took a close look at your IEC industrial product needs — and responded with unique solutions.**



Installers asked for quick, no-guesswork wiring... Plant and MRO staff asked for maximum durability and minimum downtime... And everyone wanted better selection to meet today's demanding requirements without compromise. Now take a close look at our answers: Fusible Mechanical Interlocks that cut downtime, thanks to the first-ever visible blown-fuse indication. Fusible Safety Switches with the same innovative blown-fuse-indicating LEDs. And capacities in P&S Non-Fusible Interlocks and Safety Switches.

Add proven feature-rich P&S Pin & Sleeve devices, and the result is a problem-solving IEC 309-1 and -2 product family. It's ready to work for you anywhere — because P&S IEC 309 products are guaranteed to be interchangeable with all IEC 309-1 and -2 devices, and because more than 50 countries are IEC participants, including all the world's major trading nations. As a result, manufacturers can easily standardize their electrical component specifications worldwide, simplifying purchasing, training and application to reduce costs.

P&S IEC products work for you, helping you multiply those savings — thanks to uncompromising materials and construction that deliver long-term dependability.

Take a closer look at the complete P&S IEC 309 industrial family. Compare construction, features, and specifications. Add the support of a global company, ready to help you succeed no matter where you do business. And see why this is the selection that works for you.

***Our durable, high-performance IEC 309 Industrial Products solutions have a unifying principle: Just because a device has to endure difficult conditions doesn't mean it has to be difficult to wire and use.***

## Contents

Device	Page Number
Configuration & Clocking System	J-2
Fusible Mechanical Interlock	J-3 – J-7
Non-Fusible Mechanical Interlock	J-8 – J-13
Fusible Safety Switches	J-14 – J-19
Non-Fusible Safety Switches	J-20 – J-24
Pin & Sleeve Devices	J-25 – J-31
Pin & Sleeve Devices Dimensional Information & Technical Specifications	J-32 – J-38
Product Selection Guide	J-39 – J-41

# IEC 309 Industrial Products Configuration & Clocking System

## Adapting To Worldwide Configuration Standards

### Application

Pass & Seymour/Legrand's Pin & Sleeve products are designed to meet IEC 309-1, 309-2 specifications. These specifications are recognized around the world and are intended to prevent the mating of plugs and receptacles of different voltage and current ratings (see Section 406.3(F) of the 2002 National Electrical Code® relating to this noninterchangeability feature).

### Global Product Offering

Pass & Seymour/Legrand provides IEC 309-1, 309-2 Pin & Sleeve products in both Series I (International) and Series II (North American) current ratings:

Series I (International)	16, 32, 63, 125 Amps
Series II (North American)	20, 30, 60, 100 Amps

## North American Catalog Numbering System

Catalog numbers within the North American product offering are structured to communicate the following: manufacturer, number of conductors, amperage rating, device type, clocking position of the ground sleeve, and environmental rating. This applies to all receptacles, inlets, plugs, and connectors in the Pass & Seymour/Legrand North American Pin & Sleeve product line (see sample below).

### Here's How It Works

The amperage rating is determined by the size of the device. Voltage rating is determined by the location of the ground sleeve on the receptacle and/or connector along with the number of conductors.

Ground sleeve position for all connectors and receptacles is based on a clock face with the keyway always being at 6 o'clock. The ground sleeve is positioned at a specific hour point, depending on the device's voltage rating.

The clocking position for plugs and inlets is a mirror image of the mating device, allowing for interconnection.

In addition, voltage ratings for all Pin & Sleeve products are color coded for visual identification.

## IEC 309 Clocking System

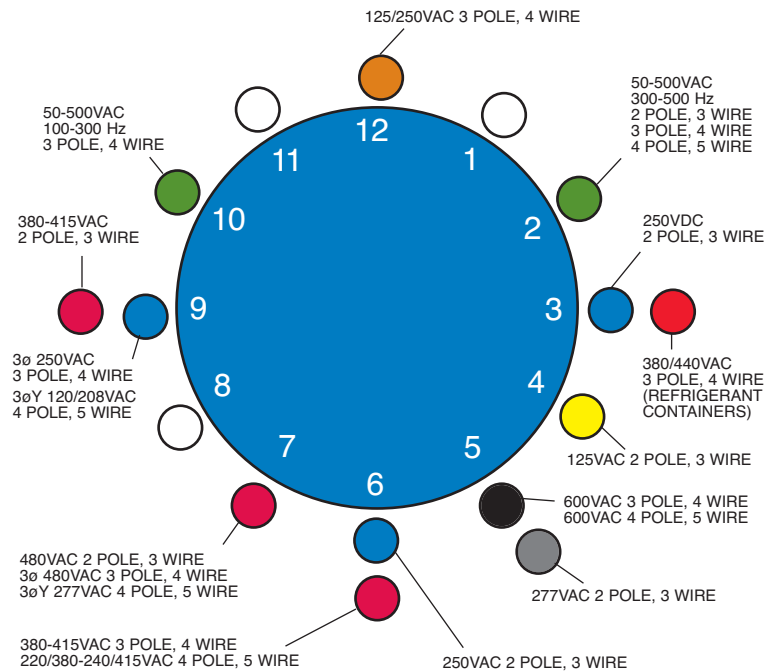

Application Specific

## North American Catalog Numbering System

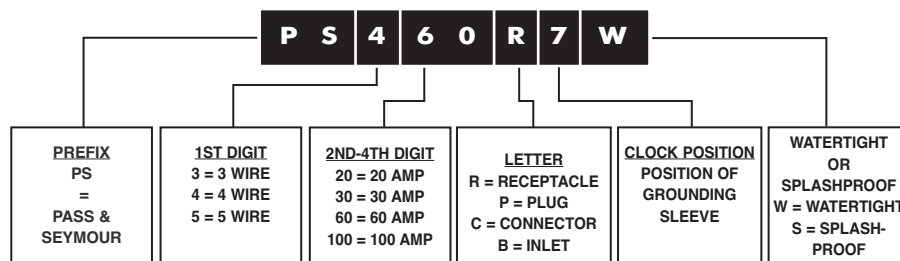

## See everything you're looking for in a Fusible Mechanical Interlock. Even if it's a blown fuse.

Introducing the first interlocks to include visible blown-fuse indication, a hinged, easy-access fuse door, and integral fuse pullers. At last, you can easily locate and replace a blown fuse in less than a minute.

Of course, saving time isn't your only challenge. You face dirt and dust. Corrosive liquids or vapors. Water or high humidity. Heat. Vibration. And impacts. No wonder ensuring safe, dependable, locally fused power to portable industrial equipment can be tough! But now, these unique P&S Fusible Mechanical Interlocks bring you a better solution.

Here's the extra-rugged construction to stand up to the toughest plant environments. Complete IEC 309 interchangeability. And an easy-installing design that fits into most I-beams. Choose these 20 to 100 amp NEMA 4X and 12 watertight-rated Fusible Mechanical Interlocks for your most demanding applications — and see how Pass & Seymour/Legrand is "The one that works for you."



Pass &amp; Seymour



## Fusible Mechanical Interlock

**Compact design** fits in most I-beams to provide mounting versatility, easy access, and reduced possibility of impact damage.

**Corrosion-resistant, stainless steel captive screws** speed installation, minimize risk of lost parts, and withstand abuse.

**Captive, quick-release, stainless steel screws** speed fuse removal, ensure a watertight access door seal, and won't fall out.

**Patent-pending integral fuse pullers** with easy-grip ergonomics make removing and replacing blown fuses simple, comfortable, and quick.

**Time-saving LED indicators** identify blown fuses at a glance.

**Hinged access door with windows** allows clear viewing of blown-fuse LED indicators and provides fast, easy access to fuse pullers.

**Heavy-duty, steel-gear switch mechanism** provides enhanced durability and extra-long service life.



## Fusible Mechanical Interlock Operating Sequence

1. When there is no plug in the device, the lock tab is in the "off" position and prevents the lock gear from turning. The handle cannot be moved to the "on" position.
2. Upon inserting a plug, the lock tab moves from the "off" position, freeing the lock gear.
3. The handle can then be moved to the "on" position. This rotates the lock gear and engages the key on the plug to prevent it from being removed. At the same time, the rack is actuated and rotates the switch gear, turning on the switch and inducing power.
4. Returning the handle to the "off" position frees the lock gear, disengaging the plug key from the switch and allowing the plug to be removed.

# Fusible Mechanical Interlock

Pass & Seymour



IEC Fusible Mechanical Interlock

**Nonconductive, watertight, corrosion- and impact-resistant Valox® enclosure** ensures NEMA 4X and 12 ratings. Withstands the harshest industrial environments.

**Heavy-duty, ergonomic switch handle** meets **OSHA Lockout/Tagout requirements** and provides plenty of grip for sure, easy operation. Black/red color coding and high-visibility ON/OFF markings clearly indicate status from a distance and at any visual angle.

**Color-coded label** clearly identifies voltage rating of mating IEC plug for fast identification.

**Durable brass/nickel-plated contacts** ensure reliable, long-lasting electrical performance and corrosion resistance.

**Completely interchangeable** with all manufacturers' IEC 309-1 and 309-2 plugs for economy and versatility.

**Adjustable mounting feet** can be moved to center of unit for instant strut- or pole-mounting without special brackets or harnesses. Oversized foot design eliminates the need for washers.

**Easy to drill for bottom wiring access, top wiring access — or both.** Only one catalog number per amp rating — simplifies ordering and provides maximum application flexibility.

**Durable, stainless steel cover-retaining chain** makes installation and maintenance more convenient.

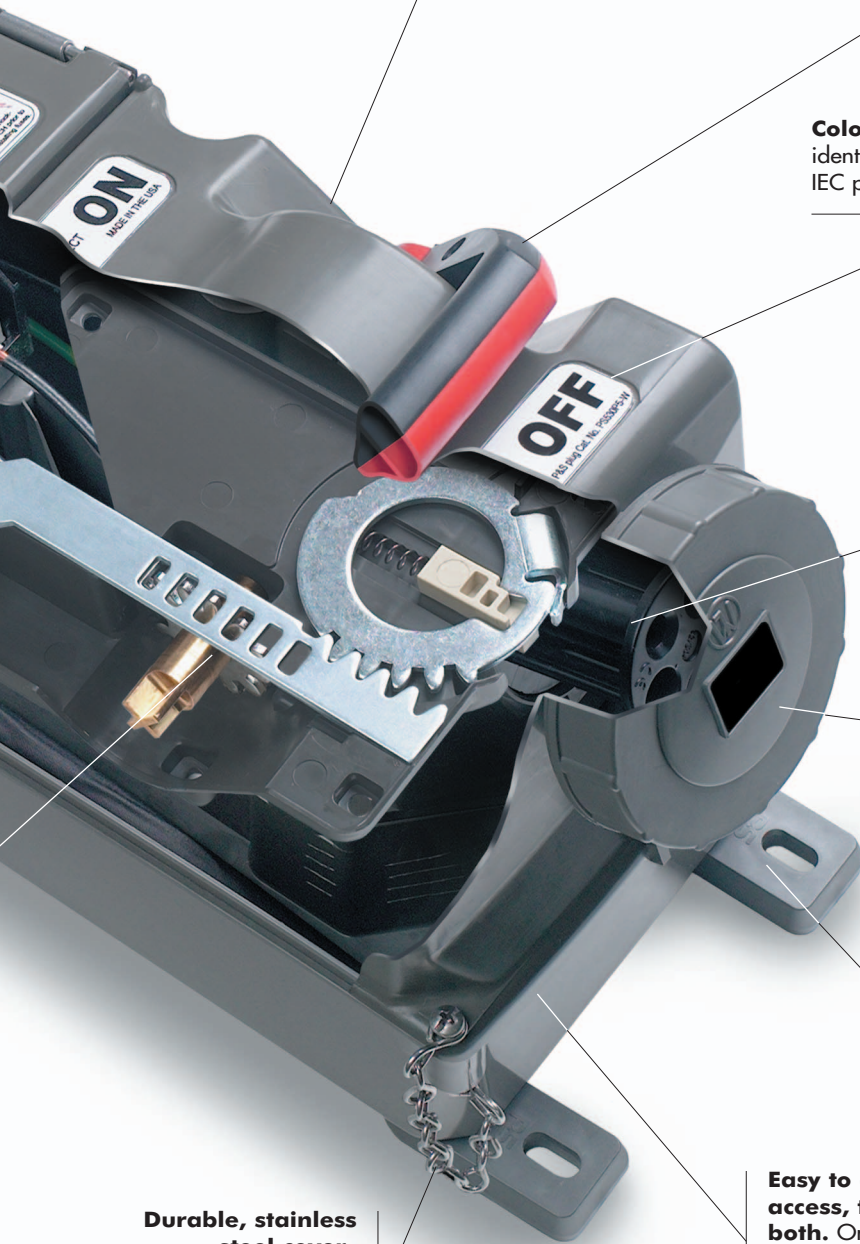

# Fusible Mechanical Interlock

## Ordering Information & Dimensions

Poles/Wires	Voltage	Standard Horsepower Rating	Maximum Horsepower Rating	Receptacle Catalog #	Pin & Sleeve Plug Catalog #	Replacement Parts		
						Cap	Fuse Puller	Door
<b>20 Amps</b>								
3P4W	120/240VAC	1/4 HP @ 120VAC	1 HP @ 120VAC	PS420FMIR12W	PS420P12W	PS420MIRWL	PSFP30	PSFD
		1/2 HP @ 208VAC	2 HP @ 208VAC					
		1/2 HP @ 240VAC	2 HP @ 240VAC					
3P4W	3ø 240VAC	1 1/2 HP	5 HP	PS420FMIR9W	PS420P9W			
3P4W	3ø 480VAC	3 HP	10 HP	PS420FMIR7W	PS420P7W			
3P4W	3ø 600VAC	5 HP	15 HP	PS420FMIR5W	PS420P5W			
<b>30 Amps</b>								
2P3W	240VAC	1 HP @ 208VAC	3 HP @ 208VAC	PS330FMIR6W	PS330P6W			
		1 1/2 HP @ 240VAC	3 HP @ 240VAC					
		1/2 HP @ 120VAC	2 HP @ 120VAC					
3P4W	120/240VAC	1 HP @ 208VAC	3 HP @ 208VAC	PS430FMIR12W	PS430P12W	PS430MIRWL	PSFP30	PSFD
		1 1/2 HP @ 240VAC	3 HP @ 240VAC					
		3 HP	7 1/2 HP	PS430FMIR9W	PS430P9W			
3P4W	3ø 240VAC	5 HP	15 HP	PS430FMIR7W	PS430P7W			
3P4W	3ø 600VAC	7 1/2 HP	15 HP	PS430FMIR5W	PS430P5W			
3P4W	3ø 440VAC	5 HP @ 380VAC	15 HP @ 380VAC	PS430FMIR3W	PS430P3W			
		5 HP @ 440VAC	15 HP @ 440VAC					
4P5W	3øY 120/208VAC	2 HP	5 HP	PS530FMIR9W	PS530P9W	PS530MIRWL	PSFP30	PSFD
4P5W	3øY 277/480VAC	5 HP	15 HP	PS530FMIR7W	PS530P7W			
4P5W	3øY 347/600VAC	7 1/2 HP	15 HP	PS530FMIR5W	PS530P5W			
<b>60 Amps</b>								
2P3W	240VAC	3 HP @ 208VAC	7 1/2 HP @ 208VAC	PS360FMIR6W	PS360P6W			
		3 HP @ 240VAC	7 1/2 HP @ 240VAC					
		1 1/2 HP @ 120VAC	3 HP @ 120VAC					
3P4W	120/240VAC	3 HP @ 208VAC	7 1/2 HP @ 208VAC	PS460FMIR12W	PS460P12W	PS60MIRWL	PSFP60	PSFD
		3 HP @ 240VAC	10 HP @ 240VAC					
		5 HP	15 HP	PS460FMIR9W	PS460P9W			
3P4W	3ø 240VAC	10 HP	30 HP	PS460FMIR7W	PS460P7W			
3P4W	3ø 600VAC	15 HP	40 HP	PS460FMIR5W	PS460P5W			
4P5W	3øY 120/208VAC	5 HP	15 HP	PS560FMIR9W	PS560P9W			
4P5W	3øY 277/480VAC	10 HP	30 HP	PS560FMIR7W	PS560P7W			
4P5W	3øY 347/600VAC	15 HP	40 HP	PS560FMIR5W	PS560P5W			
<b>100 Amps</b>								
3P4W	120/240VAC	2 HP @ 120VAC	5 HP @ 120VAC	PS4100FMIR12W	PS4100P12W	PS100MIRWL	PSFP100	PSFD100
		5 HP @ 208VAC	10 HP @ 208VAC					
		5 HP @ 240VAC	15 HP @ 240VAC					
3P4W	3ø 240VAC	10 HP	25 HP	PS4100FMIR9W	PS4100P9W			
3P4W	3ø 480VAC	20 HP	50 HP	PS4100FMIR7W	PS4100P7W			
3P4W	3ø 600VAC	30 HP	50 HP	PS4100FMIR5W	PS4100P5W			
4P5W	3øY 120/208VAC	10 HP	20 HP	PS5100FMIR9W	PS5100P9W			
4P5W	3øY 277/480VAC	20 HP	50 HP	PS5100FMIR7W	PS5100P7W			
4P5W	3øY 347/600VAC	30 HP	50 HP	PS5100FMIR5W	PS5100P5W			

(HP Ratings subject to change.)

### Fusible Mechanical Interlock Dimensions

Amps	A	B	C	D	E	F	G	H	I	J	K	L
20	9.13	1.19	10.09	23.34	24.50	1.97	4.75	6.88	7.75	20.13	22.25	23.13
3 & 4 Wire 30	9.13	1.19	9.53	23.69	24.50	1.97	4.75	6.88	7.75	20.13	22.25	23.13
5 Wire 30	9.13	1.19	9.53	23.78	24.50	1.97	4.75	6.88	7.75	20.13	22.25	23.13
60	9.13	1.19	9.94	24.59	24.50	2.25	4.75	6.88	7.75	20.13	22.25	23.13
100	11.13	1.75	11.06	27.94	28.31	2.41	6.75	8.88	9.75	23.94	26.06	26.94

All measurements shown in inches.

# Fusible Mechanical Interlock Materials of Manufacture Typical/Sample Spec

Pass & Seymour



## Typical Specifications

Manufacturer's Identification: Pass & Seymour PS560FMIR5W  
 Description: Fusible Pin & Sleeve Mechanical Interlock  
 Electrical Type: 3 Pole + Neutral + Earth  
 Rating: 60A 3Ø 600VAC 15 HP standard, 50 HP maximum  
 Configuration: IEC clock position 5  
 Enclosure Type: NEMA 4X (watertight, hosedown), 12K (dusttight, falling dirt), IP67 suitability  
 Conduit Location: Top or bottom feed. Unit shipped with no holes drilled; a top and bottom feed spot drill is provided for locating hole saw or knockout. End user decides at installation whether top or bottom feed is appropriate. No closure plug kits required.

## Materials

Enclosure Cover	Valox 357®
Enclosure Base	Valox 357®
Enclosure Door	Valox 357®
Enclosure Gasket	Neoprene
Door Hinge	316 Stainless Steel
Switch Handle	Valox 357®
Switch Handle Seal	Neoprene
Shaft	Brass
Gear Mechanism	1/8" Zinc-Plated Steel
Locktab	10% Glass-Filled Nylon
Switch Key	10% Glass-Filled Nylon
Mounting Feet	Valox 357®
Mounting Feet Screws	300 Series Stainless Steel
Enclosure Assembly Screws	300 Series Stainless Steel
Enclosure Assembly Inserts	Brass
Receptacle Lid	Valox 357®
Receptacle Gasketing	Neoprene
Receptacle Lid Hinge Spring	300 Series Stainless Steel
Receptacle Contact Carrier	Polyamide 6
Receptacle Sleeves	20-60 amp Brass/Nickel Plate 100 amp Brass/Silver Plate
Receptacle Terminal Screws	Zinc-Plated Steel
Grounding Plate	Zinc-Plated Steel
Cover Chain	300 Series Stainless Steel
Conduit Hub	Aluminum/Zinc 20/30 amp shipped with one (1) 1" 60 amp shipped with one (1) 1 1/4" 100 amp shipped with one (1) 1 1/2" (will also fit a 2" hub, not provided) 1/8" thick glass lens
Viewing Slots in Fuse-Access Door	

## Performance

### Electrical:

Fuse Type	Class "J"
Dielectric Voltage Withstand	3000V minimum
Maximum Working Voltage	600V RMS
Current Interrupting	Listed for current interrupting at full-rated current and voltage
Short Circuit Withstand Rating	For use on circuit capable of delivering not more than 10,000 RMS amps at receptacle voltage rating
Operations	Mechanical: 15,000 cycles Electrical: 10,000 cycles
Auxiliary Contacts	10A @ 600VAC 1 N.O. & 1 N.C.

### Mechanical:

Impact Resistance	Per UL746C
Terminal Identification	Per UL, CSA, and IEC specifications
Product Identification	Identification and rating on external and internal labels
Mounting	External adjustable feet with five (5) positions Can be mounted directly to channel or strut (no washers required)

### Environmental:

Moisture Resistance	Per UL50, section 35, NEMA Enclosure Type 4X (watertight, hosedown) Per UL50, section 35, NEMA Enclosure Type 12K (dusttight, falling dirt) IP67 suitability
Flammability	UL94 5VA and VO Classification
Operating Temperature	Maximum continuous: +60°C Minimum continuous: -50°C without impact
UV Resistance	All enclosure materials are UV stable

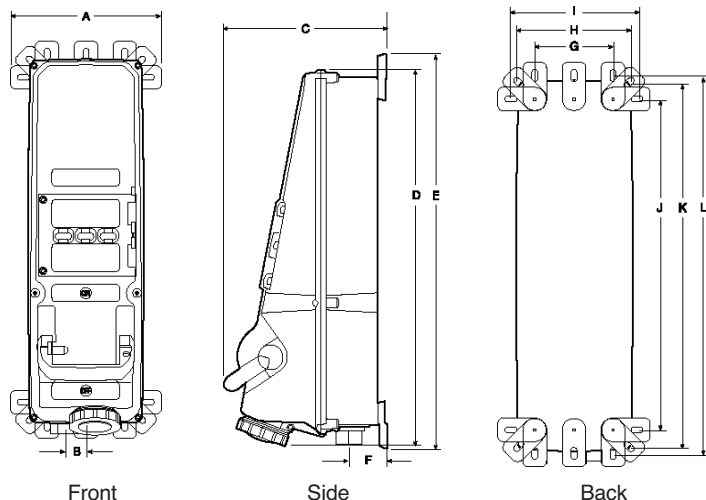

Hub shown at bottom of unit for reference only; may be field-installed for top or bottom entry.

(See dimensions on page J-6.)

Pass & Seymour



# Non-Fusible Mechanical Interlock





## Performance and quality you can see at a distance. Now take a closer look.

P&S Non-Fusible Interlocks are easy to apply, thanks to their versatile, adjustable mounting feet, compact dimensions, and flexible wiring via either top or bottom feed. And once installed, they'll withstand tough conditions — including water in wash-down areas, contamination from shavings, dirt, and dust; accidental impacts, heat from furnaces, welding or other processes; and vibration from any type of equipment.

Here's the safety that goes beyond ordinary requirements. These Interlocks feature a patent-pending, tamper-resistant activating assembly and cover-integral switch mechanism that protect against unauthorized overrides. And high-visibility ON/OFF designations plus a hefty black/red handle make status easy to read at a glance.

Take a close look at our 20 to 100 amp Non-Fusible Interlocks — and see the design and construction that works for you.

Pass &amp; Seymour



## Non-Fusible Mechanical Interlock

**Top- or bottom-feed models** offer installation flexibility and eliminate the need for time-consuming modifications like drilling and plugging that may nullify the NEMA 4X enclosure rating. Off-center cable entry directs condensation away from internal circuitry — reducing the risk of shorts and corrosion.

**Compact design** doesn't protrude, avoids unnecessary knocks, allows for versatile mounting, and fits into standard I-beams and channels.

**Stainless steel captive screws** speed up installation, minimize risk of lost parts, and resist corrosion.

**Exclusive circuit ID pad** for fast identification of the motor circuit. Accepts preprinted labels or handwritten data.

**Nonconductive, watertight, corrosion- and impact-resistant Valox® enclosure** ensures NEMA 4X and 12 ratings, withstands the harshest industrial environments.

**Adjustable mounting feet** provide optimum flexibility when mounting to equipment and walls. Feet can also be moved to center of unit, for instant strut- or pole-mounting without special brackets or harnesses. And our oversized foot design eliminates the need for washers.

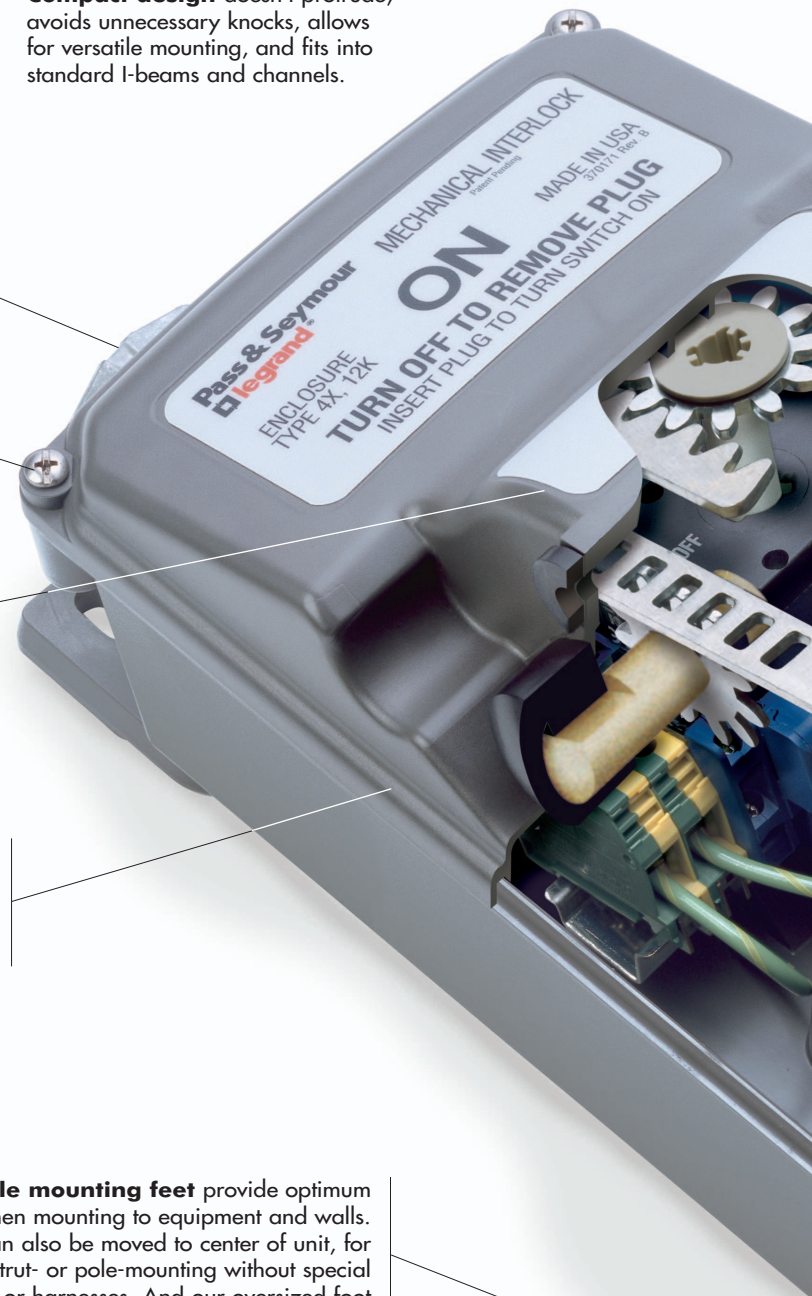

### Non-Fusible Mechanical Interlock Operating Sequence

1. When there is no plug in the device, the lock tab is in the "off" position and prevents the lock gear from turning. The handle cannot be moved to the "on" position.
2. Upon inserting a plug, the lock tab moves from the "off" position, freeing the lock gear.
3. The handle can then be moved to the "on" position. This rotates the lock gear and engages the key on the plug to prevent it from being removed. At the same time, the rack is actuated and rotates the switch gear, turning on the switch and inducing power.
4. Returning the handle to the "off" position frees the lock gear, disengaging the plug key from the switch and allowing the plug to be removed.

# Non-Fusible Mechanical Interlock

Pass & Seymour



IEC Non-Fusible Mechanical Interlock

**Handle meets OSHA Lockout/Tagout requirements.**

**Heavy-duty, lever-style switch handle** ensures a firm grip — even with wet, greasy hands. Black/red color-coded handle and high-visibility ON/OFF markings clearly indicate power supply status from a distance and from all angles. Handle enters enclosure from one side to minimize damage due to frontal impacts; entry is offset and sealed to prevent moisture contamination during washdowns.

**Label is color coded** to correspond with the voltage ratings of all mating IEC plugs for easy visual identification.

**Stainless steel cover retaining chain** allows for easy installation and maintenance.

**Durable brass/nickel-plated contacts** ensure reliable, long-lasting electrical performance and corrosion resistance.

**Completely interchangeable** with all manufacturers' IEC 309-1 and 309-2 plugs.

**Top mount auxiliary contacts are standard** to simplify ordering, purchasing, inventory, and installation requirements.

**Patent-pending, tamper-resistant activating assembly and cover-integral switch mechanism** protect against unauthorized overrides, ensuring operator safety.

Valox® is a registered trademark of the General Electric Co.

Pass &amp; Seymour



# Non-Fusible Mechanical Interlock Ordering Information & Dimensions

Poles/Wires	Voltage	Horsepower Rating	Receptacle Catalog #	Pin & Sleeve Plug Catalog #	Replacement Cap
<b>20 Amps</b>					
3P4W	120/240VAC	1 HP (120VAC); 2 HP (208-240VAC L-L)	PS420MIR12W	PS420P12W	PS420MIRWL
3P4W	3ø 240VAC	5 HP	PS420MIR9W	PS420P9W	
3P4W	3ø 480VAC	10 HP	PS420MIR7W	PS420P7W	
3P4W	3ø 600VAC	15 HP	PS420MIR5W	PS420P5W	
<b>30 Amps</b>					
2P3W	120VAC	2 HP	PS330MIR4W	PS330P4W	PS430MIRWL
3P4W	120/240VAC	2 HP (120VAC); 3 HP (208-240VAC L-L)	PS430MIR12W	PS430P12W	
3P4W	3ø 240VAC	7½ HP	PS430MIR9W	PS430P9W	
3P4W	3ø 480VAC	15 HP	PS430MIR7W	PS430P7W	
3P4W	3ø 600VAC	20 HP	PS430MIR5W	PS430P5W	
3P4W	3ø 380/440VAC	15 HP	PS430MIR3W	PS430P3W	
4P5W	3øY 120/208VAC	5 HP	PS530MIR9W	PS530P9W	PS530MIRWL
4P5W	3øY 277/480VAC	15 HP	PS530MIR7W	PS530P7W	
4P5W	3øY 347/600VAC	20 HP	PS530MIR5W	PS530P5W	
4P5W	3øY 120/208VAC	20 HP	PS530MIR3W	PS530P3W	
<b>60 Amps</b>					
2P3W	240VAC	7½ HP (208-240VAC)	PS360MIR6W	PS360P6W	PS60MIRWL
2P3W	480VAC		PS360MIR7W	PS360P7W	
3P4W	120/240VAC	3 HP (120VAC); 7½ HP (208-240VAC L-L)	PS460MIR12W	PS460P12W	
3P4W	3ø 240VAC	15 HP	PS460MIR9W	PS460P9W	
3P4W	3ø 480VAC	30 HP	PS460MIR7W	PS460P7W	
3P4W	3ø 600VAC	40 HP	PS460MIR5W	PS460P5W	
4P5W	3øY 120/208VAC	15 HP	PS560MIR9W	PS560P9W	
4P5W	3øY 277/480VAC	30 HP	PS560MIR7W	PS560P7W	
4P5W	3øY 347/600VAC	40 HP	PS560MIR5W	PS560P5W	
4P5W	3øY 120/208VAC	40 HP	PS560MIR3W	PS560P3W	
<b>100 Amps</b>					
2P3W	240VAC	10 HP (208VAC); 15 HP (240VAC)	PS3100MIR6W	PS3100P6W	PS100MIRWL
2P3W	480VAC		30 HP	PS3100MIR7W	
3P4W	3ø 600VAC	50 HP	PS4100MIR5W	PS4100P5W	
3P4W	3ø 480VAC	50 HP	PS4100MIR7W	PS4100P7W	
3P4W	3ø 240VAC	25 HP	PS4100MIR9W	PS4100P9W	
3P4W	120/240VAC	5 HP (120VAC); 10 HP (208VAC L-L); 15 HP (240VAC L-L)	PS4100MIR12W	PS4100P12W	
4P5W	3øY 347/600VAC	50 HP	PS5100MIR5W	PS5100P5W	
4P5W	3øY 277/480VAC	50 HP	PS5100MIR7W	PS5100P7W	
4P5W	3øY 120/208VAC	20 HP	PS5100MIR9W	PS5100P9W	

All products are top or bottom feed.

Unit shipped with no holes drilled; a top and bottom feed spot drill is provided for locking hole saw or knockout. End user decides whether top or bottom feed is appropriate.

No closure plug kits required. HP ratings subject to change.

## Non-Fusible Mechanical Interlock Dimensions

Amps	A	B	C	D	E	F	G	H	I	J	K	L
20	1.38	6.88	9.13	8.00	12.38	11.06	4.75	6.88	7.75	8.00	10.13	11.00
30	1.38	6.88	9.13	8.25	12.38	11.50	4.75	6.88	7.75	8.00	10.13	11.00
60	1.19	6.88	9.13	9.00	13.63	14.13	4.75	6.88	7.75	9.75	11.88	12.75
100	1.19	6.88	9.13	9.50	14.13	14.13	4.75	6.88	7.75	9.75	11.88	12.75

All measurements shown in inches.

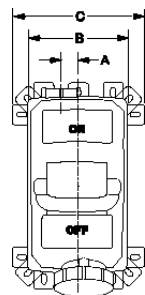

Front

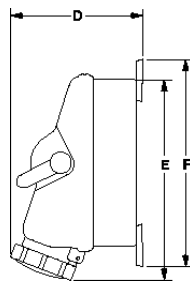

Side

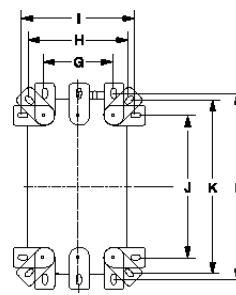

Back

(See dimensions above.)

# Non-Fusible Mechanical Interlock Materials of Manufacture Typical/Sample Spec

Pass & Seymour



## Typical Specifications

Manufacturer's Identification: Pass & Seymour PS560MIR5W  
 Description: Non-Fusible Pin & Sleeve Mechanical Interlock  
 Electrical Type: 3 Pole + Neutral + Earth  
 Rating: 60A 3ø 600VAC 15 HP standard, 40 HP maximum  
 Configuration: IEC clock position 5  
 Enclosure Type: NEMA 4X (watertight, hosedown), 12K (dusttight, falling dirt), IP67 suitability  
 Conduit Location: Top or bottom feed. Unit shipped with no holes drilled; a top and bottom feed spot drill is provided for locating hole saw or knockout. End user decides at installation whether top or bottom feed is appropriate. No closure plug kits required.

Materials	
Enclosure Cover	Valox 357®
Enclosure Base	Valox 357®
Enclosure Gasket	Neoprene
Switch Handle	Valox 357®
Switch Handle Seal	Neoprene
Shaft	Brass
Gear Mechanism	1/8" Zinc-Plated Steel
Locktab	10% Glass-Filled Nylon
Switch Key	10% Glass-Filled Nylon
Mounting Feet	Valox 357®
Mounting Feet Screws	300 Series Stainless Steel
Enclosure Assembly Screws	300 Series Stainless Steel
Enclosure Assembly Inserts	Brass
Receptacle Lid	Valox 357®
Receptacle Gasketing	Neoprene
Receptacle Lid Hinge Spring	300 Series Stainless Steel
Receptacle Contact Carrier	Polyamide 6
Receptacle Sleeves	Brass/Nickel Plate
Receptacle Terminal Screws	Zinc-Plated Steel
Grounding Plate	Zinc-Plated Steel
Cover Chain	300 Series Stainless Steel
Conduit Hub	Aluminum/Zinc
	20/30 amp shipped with one (1) 1"
	60 amp shipped with one (1) 1 1/4"
	100 amp shipped with one (1) 1 1/2"
	(will also fit a 2" hub, not provided)

Performance	
<b>Electrical:</b>	
Dielectric Voltage Withstand	3000V minimum
Maximum Working Voltage	600V RMS
Current Interrupting	Listed for current interrupting at full-rated current and voltage
Short Circuit Withstand Rating	For use on circuit capable of delivering not more than 10,000 RMS amps at receptacle voltage rating
Operations	Mechanical: 15,000 cycles Electrical: 10,000 cycles
Auxiliary Contacts	10A @ 600VAC 1 N.O. & 1 N.C.
<b>Mechanical:</b>	
Impact Resistance	Per UL746C
Terminal Identification	Per UL, CSA, and IEC specifications
Product Identification	Identification and rating on external and internal labels
Mounting	External adjustable feet with five (5) positions Can be mounted directly to channel or strut (no washers required)
<b>Environmental:</b>	
Moisture Resistance	Per UL50, section 35, NEMA Enclosure Type 4X (watertight, hosedown) Per UL50, section 35, NEMA Enclosure Type 12K (dusttight, falling dirt) IP67 suitability
Flammability	UL94 5VA and VO Classification
Operating Temperature	Maximum continuous: +60°C Minimum continuous: -50°C without impact
UV Resistance	All enclosure materials are UV stable



Machine 2

Pass & Seymour FUSED SAFETY SWITCH  
TURN OFF TO REMOVE PLUG OR OPEN FUSE ACCESS DOOR.  
TO TURN SWITCH ON, CLOSE FUSE ACCESS DOOR AND INSERT PLUG.

BLOWN FUSE INDICATION  
LED bulb inside switch is ON indicates blown fuse

<b>CAUTION</b> Risk of electric shock. Do not touch energized parts. Do not repair or tamper with equipment unless qualified personnel are instructed to do so.	<b>PRECAUTION</b> Risk of electric shock. Do not touch energized parts. Do not repair or tamper with equipment unless qualified personnel are instructed to do so.	<b>ATTENTION</b> Risk of electric shock. Do not touch energized parts. Do not repair or tamper with equipment unless qualified personnel are instructed to do so.
<b>DANGER</b> Risk of electric shock. Do not touch energized parts. Do not repair or tamper with equipment unless qualified personnel are instructed to do so.	<b>DANGER</b> Risk of electric shock. Do not touch energized parts. Do not repair or tamper with equipment unless qualified personnel are instructed to do so.	<b>DANGER</b> Risk of electric shock. Do not touch energized parts. Do not repair or tamper with equipment unless qualified personnel are instructed to do so.

ENCLOSURE TYPE 4X, 12K  
MANUAL MOTOR CONTROLLER  
NOT SUITABLE AS MOTOR DISCONNECT  
LISTED TETA  
MADE IN THE USA

ON

PS30FSS  
30A 3ØY 347/600 VAC  
7.5 I.P. STD  
20 H.P. MAX

OFF



## See blown fuses at a glance in these Fusible Safety Switches.

Looking for safety switches that cut downtime? Take a close look at these innovative P&S Fusible Safety Switches. Here's the same first-ever blown-fuse indication system that's in our pacesetter Fusible Mechanical Interlocks — with individual LED indicators for each line, patent-pending integral fuse pullers, and a hinged fuse-access door. That means no time lost to locating a blown fuse — and no time wasted in fuse replacement.

P&S Fusible Safety Switches deliver the same ultra-heavy-duty construction as our Fusible Mechanical Interlocks, too. So they provide maximum protection against water, dirt, heat, and vibration — and just about any other harsh condition you'll encounter. You get the same installation flexibility, too. With capacities available from 30 to 100 amps, there's a P&S Fusible Safety Switch that's ready to work for you in any industrial environment.

Pass &amp; Seymour



## Fusible Safety Switches

**Compact design** fits in most I-beams to provide mounting versatility, easy access, and reduced possibility of impact damage.

**Corrosion-resistant, stainless steel captive screws** speed installation, minimize risk of lost parts, and withstand abuse.

**Captive, quick-release, stainless steel screws** speed fuse removal, ensure a watertight access door seal, and won't fall out.

**Patent-pending integral fuse pullers** with easy-grip ergonomics make removing and replacing blown fuses simple, comfortable, and quick.

**Time-saving LED indicators** identify blown fuses at a glance.

**Nonconductive, watertight, corrosion- and impact-resistant Valox® enclosure** ensures NEMA 4X and 12 ratings. Withstands the harshest industrial environments.

**Hinged access door with windows** allows clear viewing of blown-fuse LED indicators and provides fast, easy access to fuse pullers.



## Fusible Safety Switches

Pass & Seymour

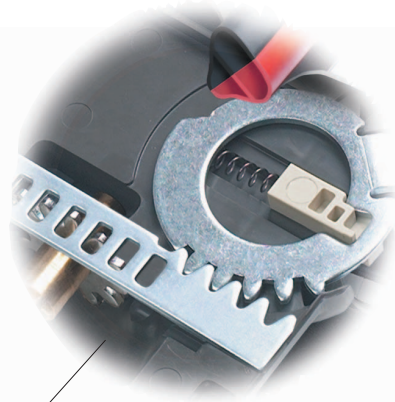

**Heavy-duty, steel-gear switch mechanism** provides enhanced durability and extra-long service life.

**Heavy-duty, ergonomic switch handle** meets OSHA Lockout/Tagout requirements and provides plenty of grip for sure, easy operation. Black/red color coding and high-visibility ON/OFF markings clearly indicate status from a distance and at any visual angle.



**Adjustable mounting feet** can be moved to center of unit for instant strut- or pole-mounting without special brackets or harnesses. Oversized foot design eliminates the need for washers.

**Easy to drill for bottom wiring access, top wiring access — or both.** Only one catalog number per amp rating — simplifies ordering and provides maximum application flexibility.

**Durable, stainless steel cover-retaining chain** makes installation and maintenance more convenient.

Pass &amp; Seymour



# Fusible Safety Switches

## Ordering Information & Dimensions

Voltage	Standard Horsepower Rating	Maximum Horsepower Rating	Fusible Safety Switch Catalog #	Replacement Parts	
				Fuse Puller	Door
<b>30 Amps 600VAC</b>					
120VAC	1/2 HP	2 HP	PS30FSS	PSFP30	PSFD
208VAC	1 HP	5 HP			
240VAC	1 1/2 HP	5 HP			
277VAC	1 1/2 HP	5 HP			
480VAC	3 HP	10 HP			
120/240VAC	1/2 HP @ 120VAC 1 1/2 HP @ 240VAC	2 HP @ 120VAC 5 HP @ 240VAC			
3ø 240VAC	3 HP	10 HP			
3ø 480VAC	5 HP	20 HP			
3ø 600VAC	7 1/2 HP	20 HP			
3øY 120/208VAC	2 HP	7 1/2 HP			
3øY 277/480VAC	5 HP	20 HP			
3øY 347/600VAC	7 1/2 HP	20 HP			
<b>60 Amps 600VAC</b>					
120VAC	1 1/2 HP	3 HP	PS60FSS	PSFP60	PSFD
208VAC	3 HP	7 1/2 HP			
240VAC	3 HP	10 HP			
277VAC	3 HP	10 HP			
480VAC	5 HP	20 HP			
120/240VAC	1 1/2 HP @ 120VAC 3 HP @ 240VAC	3 HP @ 120VAC 10 HP @ 240VAC			
3ø 240VAC	5 HP	20 HP			
3ø 480VAC	10 HP	40 HP			
3ø 600VAC	15 HP	50 HP			
3øY 120/208VAC	5 HP	20 HP			
3øY 277/480VAC	10 HP	40 HP			
3øY 347/600VAC	15 HP	50 HP			
<b>100 Amps 600VAC</b>					
120VAC	2 HP	5 HP	PS100FSS	PSFP100	PSFD100
208VAC	5 HP	10 HP			
240VAC	5 HP	15 HP			
277VAC	7 1/2 HP	15 HP			
480VAC	10 HP	30 HP			
120/240VAC	2 HP @ 120VAC 5 HP @ 240VAC	5 HP @ 120VAC 15 HP @ 240VAC			
3ø 240VAC	10 HP	25 HP			
3ø 480VAC	20 HP	50 HP			
3ø 600VAC	30 HP	50 HP			
3øY 120/208VAC	10 HP	20 HP			
3øY 277/480VAC	20 HP	50 HP			
3øY 347/600VAC	30 HP	50 HP			

(HP Ratings subject to change.)

Hub shown at bottom of unit for reference only; may be field-installed for top or bottom entry.

(See dimensions below.)



Front

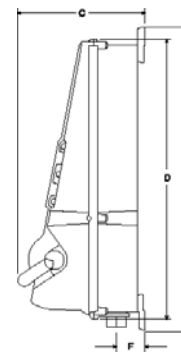

Side

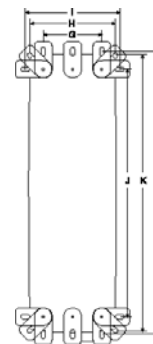

Back

### Fusible Safety Switches Dimensions

Amps	A	B	C	D	E	F	G	H	I	J	K	L
30	9.13	1.19	10.09	22.59	22.59	1.97	4.75	6.88	7.75	20.13	22.25	23.13
60	9.13	1.19	10.09	22.59	22.59	2.25	4.75	6.88	7.75	20.13	22.25	23.13
100	11.13	1.75	11.06	26.59	28.31	2.41	6.75	8.88	9.75	23.94	26.06	26.94

All measurements shown in inches.

# Fusible Safety Switches Materials of Manufacture Typical/Sample Spec

Pass & Seymour



## Typical Specifications

Manufacturer's Identifications: Pass & Seymour PS60FSS  
 Description: Fusible Safety Switch  
 Rating: 60A, 600VAC maximum  
 Enclosure Type: NEMA 4X (watertight, hosedown), 12K (dusttight, falling dirt), IP67 suitability  
 Conduit Location: Top or bottom feed. Unit shipped with no holes drilled; a top and bottom feed spot drill is provided for locating hole saw or knockout. End user decides at installation whether top or bottom feed is appropriate. No closure plug kits required.

## Materials

Enclosure Cover	Valox 357®
Enclosure Base	Valox 357®
Enclosure Door	Valox 357®
Enclosure Gasket	Neoprene
Door Hinge	316 Stainless Steel
Switch Handle	Valox 357®
Switch Handle Seal	Neoprene
Shaft	Brass
Gear Mechanism	1/8" Zinc-Plated Steel
Switch Key	10% Glass-Filled Nylon
Mounting Feet	Valox 357®
Mounting Feet Screws	300 Series Stainless Steel
Enclosure Assembly Screws	300 Series Stainless Steel
Enclosure Assembly Inserts	Brass
Grounding Plate	Zinc-Plated Steel
Cover Chain	300 Series Stainless Steel
Conduit Hub	Aluminum/Zinc
	30 amp shipped with one (1) 1"
	60 amp shipped with one (1) 1 1/4"
	100 amp shipped with one (1) 1 1/2" (will also fit a 2" hub, not provided)
Viewing Slots in Fuse-Access Door	1/8" thick glass lens

## Performance

<b>Electrical:</b>	
Fuse Type	Class "J"
Dielectric Voltage Withstand	3000V minimum
Maximum Working Voltage	600V RMS
Current Interrupting	Listed for current interrupting at full-rated current and voltage
Short Circuit Withstand Rating	For use on circuit capable of delivering not more than 10,000 RMS amps at receptacle voltage rating
Operations	Mechanical: 15,000 cycles Electrical: 10,000 cycles
Auxiliary Contacts	10A @ 600VAC 1 N.O. & 1 N.C.
<b>Mechanical:</b>	
Impact Resistance	Per UL746C
Terminal Identification	Per UL and CSA
Product Identification	Identification and rating on external and internal labels
Mounting	External adjustable feet with five (5) positions Can be mounted directly to channel or strut (no washers required)
<b>Environmental:</b>	
Moisture Resistance	Per UL50, section 35, NEMA Enclosure Type 4X (watertight, hosedown) Per UL50, section 35, NEMA Enclosure Type 12K (dusttight, falling dirt) IP67 suitability
Flammability	UL94 5VA and VO Classification
Operating Temperature	Maximum continuous: +60°C Minimum continuous: -50°C without impact
UV Resistance	All enclosure materials are UV stable

Pass &amp; Seymour



Non-Fusible Safety Switches

## Non-Fusible Safety Switches UL Listed as “Suitable as Motor Disconnect.”

Here’s the first non-metallic NEMA 4X Non-Fusible Safety Switch line UL Listed as “Suitable as Motor Disconnect” — per 2002 NEC® Article 430.109(A)(6).

P&S Non-Fusible Safety Switches feature extra-tough components, including an impact-resistant Valox® NEMA 4X enclosure. And an innovative design that delivers safe, sure operation under the worst conditions. These rugged performers are available in capacities from 30 to 100 amps.

And when you take a closer look, you’ll see even more to like. For example, the fits-anywhere compact design. The adjustable mounting feet that speed installation. Or the no-confusion, at-a-glance ON/OFF status indication.

See how P&S Non-Fusible Safety Switches work better for you.

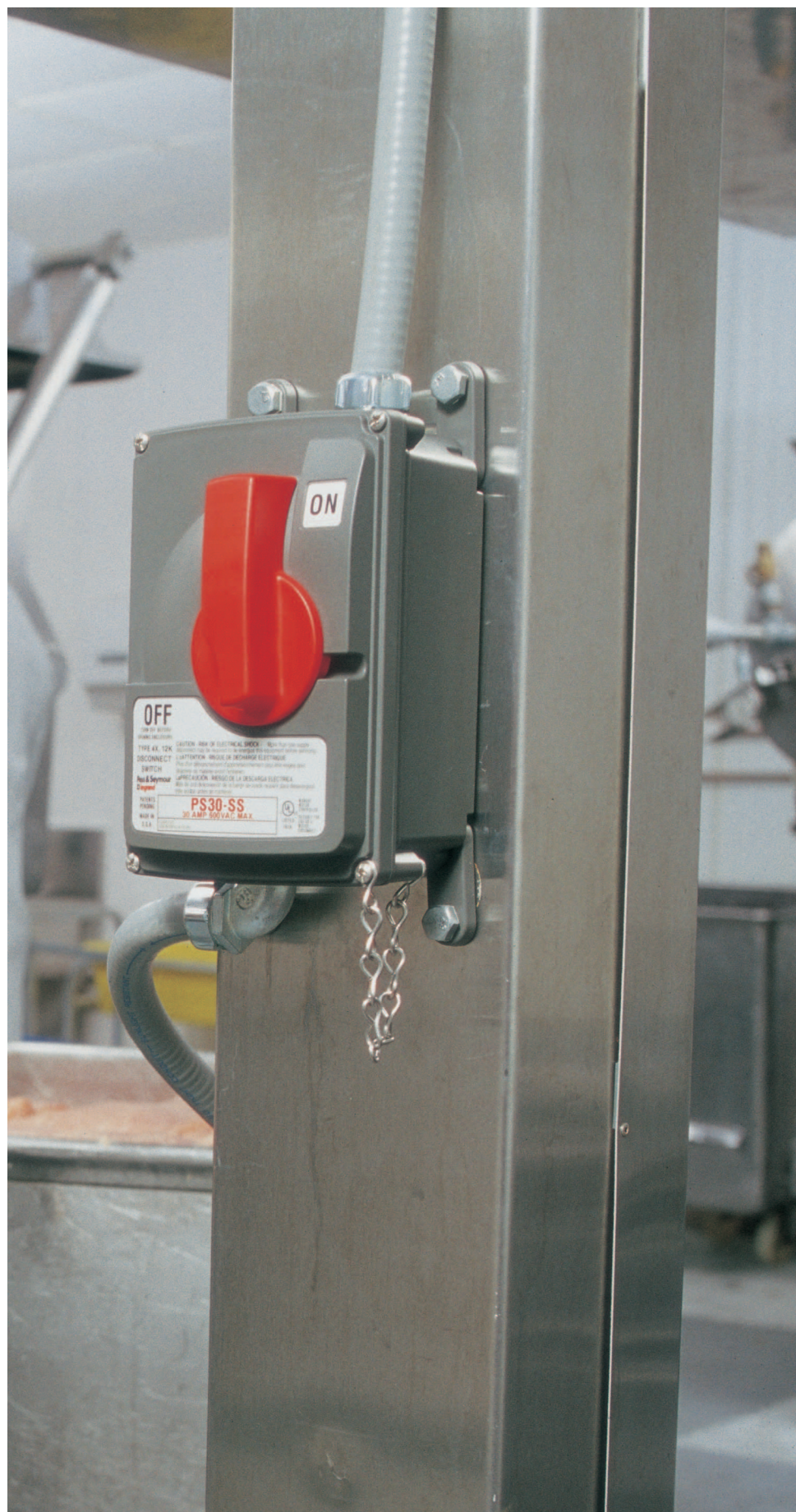

# Non-Fusible Safety Switches

Pass & Seymour



**Compact design** fits in most I-beams to provide mounting versatility, easy access, and reduced possibility of impact damage.

**Heavy-duty, ergonomic switch handle meets OSHA Lockout/Tagout provisions** and provides plenty of grip for sure, easy operation. Black/red color coding and high-visibility ON/OFF markings clearly indicate status from a distance and at any visual angle. Switch entry into the enclosure is offset to the side and sealed to provide enhanced water resistance.

**Nonconductive, watertight, corrosion-, heat-, and impact-resistant thermoplastic enclosure** ensures NEMA 4X and 12 ratings. Withstands the harshest industrial environments.

**Durable, stainless steel cover-retaining chain** makes installation and maintenance more convenient.



**Corrosion-resistant, stainless steel captive screws** speed installation, minimize risk of lost parts, and withstand abuse.

**Bottom and top wiring access options.** No unnecessary openings to compromise water resistance.

**Adjustable mounting feet** can be moved to center of unit for instant strut- or pole-mounting without special brackets or harnesses.

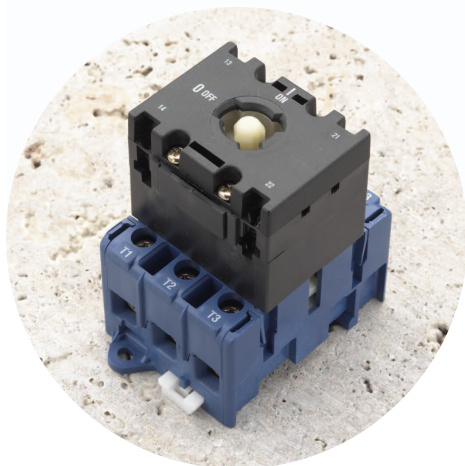

**Top mount auxiliary contact** enables additional control functions or signal lights.

# Non-Fusible Safety Switches Ordering Information

Voltage	Maximum Horsepower Rating	Non-Fusible Safety Switch Catalog #	Non-Fusible Safety Switch with Auxiliary Contact Catalog #	Auxiliary Contact Kit*	Replacement Switches
<b>30 Amps 600VAC</b>					
120VAC	1 HP	PS30SS	PS30SSAX	AX30	RS30
208VAC	2 HP				
240VAC	3 HP				
277VAC	3 HP				
480VAC	5 HP				
3ø 240VAC	5 HP				
3ø 480VAC	10 HP				
3ø 600VAC	10 HP				
3øY 120/208VAC	5 HP				
3øY 277/480VAC	10 HP				
3øY 347/600VAC	10 HP				
<b>60 Amps 600VAC</b>					
120VAC	3 HP	PS60SS	PS60SSAX	AX60	RS60
208VAC	10 HP				
240VAC	10 HP				
277VAC	15 HP				
480VAC	20 HP				
3ø 240VAC	20 HP				
3ø 480VAC	40 HP				
3ø 600VAC	50 HP				
3øY 120/208VAC	20 HP				
3øY 277/480VAC	40 HP				
3øY 347/600VAC	50 HP				
<b>100 Amps 600VAC</b>					
120VAC	5 HP	PS100SS	PS100SSAX	AX60	RS100
208VAC	10 HP				
240VAC	15 HP				
277VAC	15 HP				
480VAC	30 HP				
3ø 240VAC	25 HP				
3ø 480VAC	50 HP				
3ø 600VAC	50 HP				
3øY 120/208VAC	20 HP				
3øY 277/480VAC	50 HP				
3øY 347/600VAC	50 HP				

\*For replacement of side mount auxiliary contact on previous design.

## Mounting Feet Replacement Kit

Catalog Number	Description
SSMF	Mounting Feet Replacement Kit for PS30SS and PS30SSAX

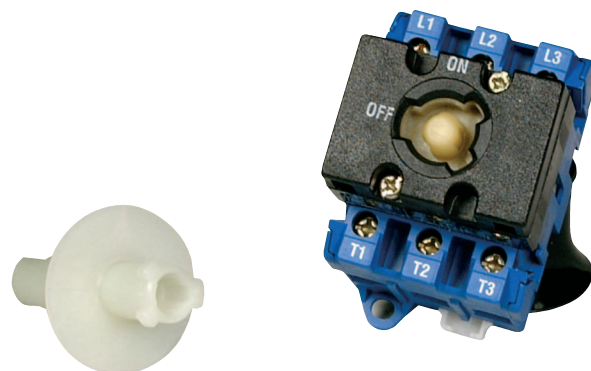

RS30



AX30

# Non-Fusible Safety Switches Materials of Manufacture Typical/Sample Spec

Pass & Seymour



## Typical Specifications

Manufacturer's Identification: Pass & Seymour PS60SS  
 Description: Non-Fusible Safety Switch  
 Rating: 60A, 600VAC maximum  
 Enclosure Type: NEMA 4X (watertight, hosedown), 12K (dusttight, falling dirt), IP67 suitability  
 Conduit Location: Top, bottom, or back feed. Units are shipped without holes for conduit. Spot drills for locating hole saw or knockouts are provided for top, bottom, or back feed. End user decides at installation whether top, bottom, or back feed is appropriate. No closure plug kits required. Units are not provided with conduit hubs.

## Materials

Enclosure Cover	Valox 357®
Enclosure Base	Valox 357®
Enclosure Gasket	Neoprene
Switch Handle	Valox 357®
Switch Handle Seal	Neoprene
Switch Key	10% Glass-Filled Nylon
Mounting Feet	Valox 357®
Mounting Feet Screws	300 Series Stainless Steel
Enclosure Assembly Screws	300 Series Stainless Steel
Enclosure Assembly Inserts	Brass (60 and 100 amp units only)
Grounding Plate	Galvanized Steel
Cover Chain	300 Series Stainless Steel

## Performance

### Electrical:

Dielectric Voltage Withstand	3000V minimum
Maximum Working Voltage	600V RMS
Current Interrupting	Listed for current interrupting at full-rated current and voltage
Short Circuit Withstand Rating	For use on circuit capable of delivering not more than (see chart below) RMS amps at 600VAC
Operations	Mechanical: 15,000 cycles Electrical: 10,000 cycles
Auxiliary Contacts (optional)	10A @ 600VAC 1 N.O. & 1 N.C.

## Interrupting Ratings — RMS Symmetrical Amperes

Suitable for use on circuits capable of delivering not more than (see chart below for cat. no. and application) RMS symmetrical amperes, 600VAC maximum.

Catalog Number	Manual Motor Controller	Motor Disconnect
PS30SS (AX)	10,000 AMP	10,000 AMP
PS60SS (AX)	10,000 AMP	5,000 AMP
PS100SS (AX)		

### Mechanical:

Impact Resistance	Per UL746C
Terminal Identification	Per UL and CSA
Product Identification	Identification and rating on external and internal labels
Mounting	External adjustable feet with five (5) positions Can be mounted directly to channel or strut (no washers required)

### Environmental:

Moisture Resistance	Per UL50, section 35, NEMA Enclosure Type 4X (watertight, hosedown) Per UL50, section 35, NEMA Enclosure Type 12K (dusttight, falling dirt) • IP67 suitability
Flammability	UL94 5VA and VO Classification
Operating Temperature	Maximum continuous: +60°C • Minimum continuous: -50°C without impact
UV Resistance	All enclosure materials are UV stable

# Non-Fusible Safety Switches Dimensions

## Non-Fusible Safety Switches Dimensions

Amps	A	B	C	D	E	F	G	H	I	J	K
30	5.75	7.38	4.88	7.19	9.69	3.75	5.75	6.56	6.13	8.06	8.88
60	7.19	9.13	6.31	9.63	12.38	4.75	7.19	8.13	8.00	10.38	11.38
100	7.19	9.13	6.31	9.63	12.38	4.75	7.19	8.13	8.00	10.38	11.38

All measurements shown in inches.

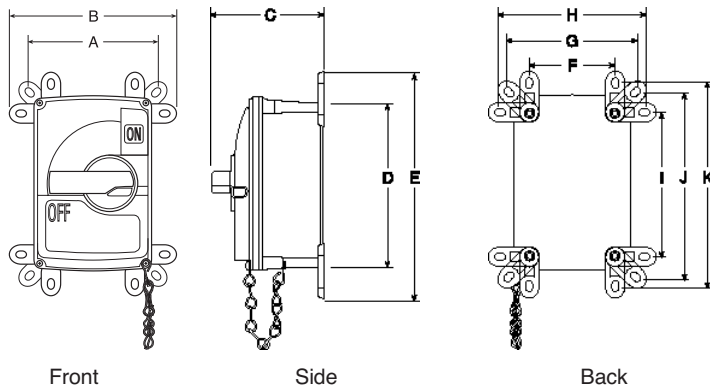

(See dimensions above.)

## Take a closer look at fast-installing Pin & Sleeve products that work for you.

There's no better protection against moisture and industrial contaminants than P&S IEC Pin & Sleeve products. With spring-loaded covers, locking rings, and neoprene gaskets, everything from water to dirt is completely shut out of the electrical system — even if the connection is accidentally submerged!

All P&S Watertight Pin & Sleeve plugs, connectors, receptacles, and inlets bring you the features to enhance versatility, reliability, and safety. For example, North American products come completely ready to wire, for quick, simple installation. And all feature impact- and chemical-resistant thermoplastic construction. Shrouded, nickel-plated, solid-brass pins provide corrosion protection and excellent conductivity. And an exclusive, hinged cord grip eliminates loose parts that get lost.

With a complete range of choices rated from 20 to 100 amps, you'll find a Pass & Seymour/Legrand works-for-you solution for every Pin & Sleeve application in and around your plant.

Pass &amp; Seymour



## Pin &amp; Sleeve Devices

**Ratings, compliances visible**  
on strap for fast, long-lasting I.D.

**Arrives ready to wire, with cord grip open** and cable-ready; terminal screws come backed out and ready to wire; front and back body require no disassembly prior to assembly.

**Cover with integral neoprene gasket** provides watertight seal.

**Revolutionary, hinged cord grip** for durable performance and ease of installation.

**Combination-head screws** for added convenience and quick installation.

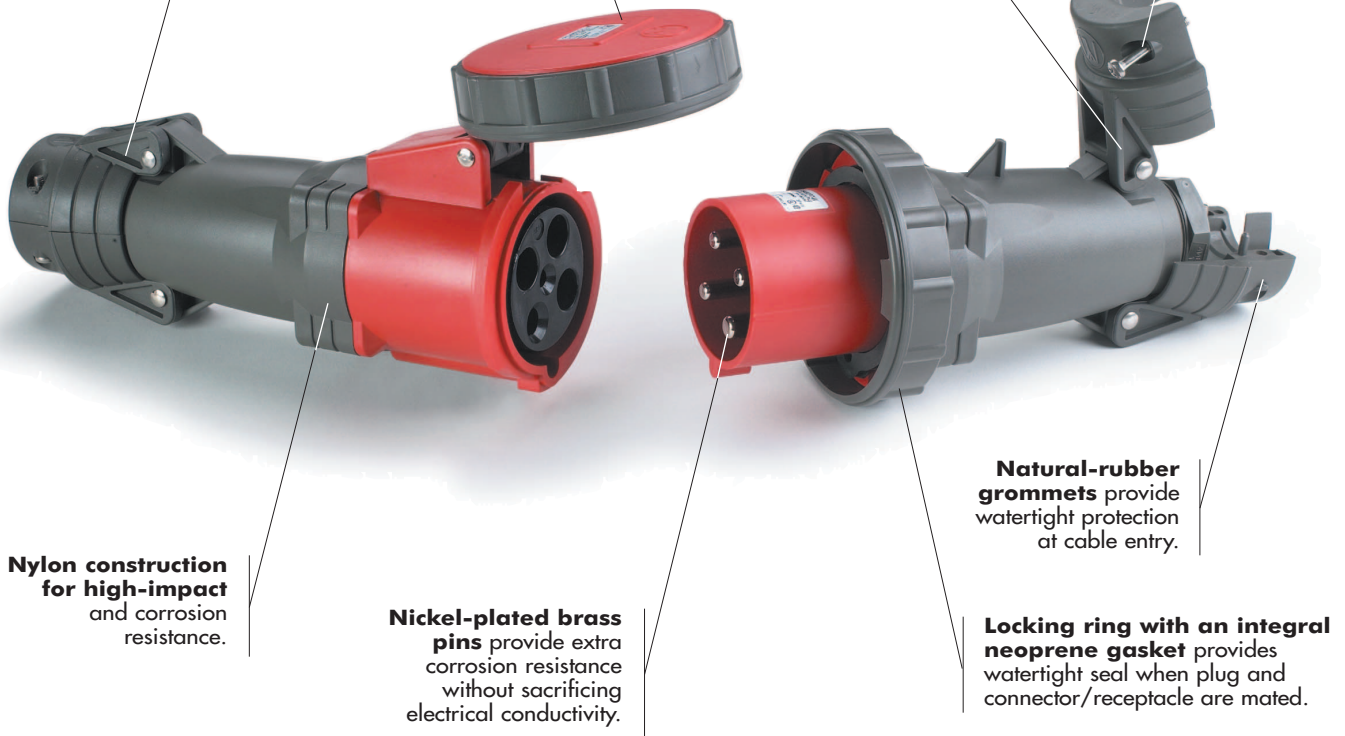

**P&S Pin & Sleeve products provide installation ease,** enduring performance in harsh conditions, and guaranteed IEC 309 compatibility.

# Pin & Sleeve Devices North American Watertight Devices Ordering Information

Pass & Seymour



IEC Pin & Sleeve Watertight Devices

## North American Product Offering

<b>IP67</b> Suitability				Watertight			Back Boxes		Replacement Parts				
Poles & Wires	Configuration		Voltage/ Color Coding	Receptacle	Plug	Connector	Metallic Back Box	Non-Metallic Back Box	Bodies		Caps		
	Recep./ Conn.	Plug/ Inlet							Plug	Connector	Receptacle	Connector	
<b>20 Amps</b>													
2P3W			125	PS320R4W	PS320P4W	PS320C4W	PSBB201W	PSBBN201W	PS320P4WR	PS320C4WR	PS320R4WL	PS320C4WL	
2P3W			250	PS320R6W	PS320P6W	PS320C6W	PSBB201W	PSBBN201W	PS320P6WR	PS320C6WR	PS320R6WL	PS320C6WL	
2P3W			480	PS320R7W	PS320P7W	PS320C7W	PSBB201W	PSBBN201W	PS320P7WR	PS320C7WR	PS320R7WL	PS320C7WL	
2P3W			277	PS320R5W	PS320P5W	PS320C5W	PSBB201W	PSBBN201W	PS320P5WR	PS320C5WR	PS320R5WL	PS320C5WL	
3P4W			125/250	PS420R12W	PS420P12W	PS420C12W	PSBB202W	PSBBN202W	PS420P12WR	PS420C12WR	PS420R12WL	PS420C12WL	
3P4W			3ø 250	PS420R9W	PS420P9W	PS420C9W	PSBB202W	PSBBN202W	PS420P9WR	PS420C9WR	PS420R9WL	PS420C9WL	
3P4W			3ø 480	PS420R7W	PS420P7W	PS420C7W	PSBB202W	PSBBN202W	PS420P7WR	PS420C7WR	PS420R7WL	PS420C7WL	
3P4W			3ø 600	PS420R5W	PS420P5W	PS420C5W	PSBB202W	PSBBN202W	PS420P5WR	PS420C5WR	PS420R5WL	PS420C5WL	
4P5W			3øY 120/208	PS520R9W	PS520P9W	PS520C9W	PSBB202W	PSBBN202W	PS520P9WR	PS520C9WR	PS520R9WL	PS520C9WL	
4P5W			3øY 277/480	PS520R7W	PS520P7W	PS520C7W	PSBB202W	PSBBN202W	PS520P7WR	PS520C7WR	PS520R7WL	PS520C7WL	
4P5W			3øY 347/600	PS520R5W	PS520P5W	PS520C5W	PSBB202W	PSBBN202W	PS520P5WR	PS520C5WR	PS520R5WL	PS520C5WL	
<b>30 Amps</b>													
2P3W			125	PS330R4W	PS330P4W	PS330C4W	PSBB301W	PSBBN301W	PS330P4WR	PS330C4WR	PS330R4WL	PS330C4WL	
2P3W			250	PS330R6W	PS330P6W	PS330C6W	PSBB301W	PSBBN301W	PS330P6WR	PS330C6WR	PS330R6WL	PS330C6WL	
2P3W			480	PS330R7W	PS330P7W	PS330C7W	PSBB301W	PSBBN301W	PS330P7WR	PS330C7WR	PS330R7WL	PS330C7WL	
3P4W			125/250	PS430R12W	PS430P12W	PS430C12W	PSBB301W	PSBBN301W	PS430P12WR	PS430C12WR	PS430R12WL	PS430C12WL	
3P4W			3ø 250	PS430R9W	PS430P9W	PS430C9W	PSBB301W	PSBBN301W	PS430P9WR	PS430C9WR	PS430R9WL	PS430C9WL	
3P4W			3ø 480	PS430R7W	PS430P7W	PS430C7W	PSBB301W	PSBBN301W	PS430P7WR	PS430C7WR	PS430R7WL	PS430C7WL	
3P4W			3ø 600	PS430R5W	PS430P5W	PS430C5W	PSBB301W	PSBBN301W	PS430P5WR	PS430C5WR	PS430R5WL	PS430C5WL	
3P4W*			380/440	PS430R3W	PS430P3W	PS430C3W	PSBB301W	PSBBN301W	PS430P3WR	PS430C3WR	PS430R3WL	PS430C3WL	
4P5W			3øY 120/208	PS530R9W	PS530P9W	PS530C9W	PSBB301W	PSBBN301W	PS530P9WR	PS530C9WR	PS530R9WL	PS530C9WL	
4P5W			3øY 277/480	PS530R7W	PS530P7W	PS530C7W	PSBB301W	PSBBN301W	PS530P7WR	PS530C7WR	PS530R7WL	PS530C7WL	
4P5W			3øY 347/600	PS530R5W	PS530P5W	PS530C5W	PSBB301W	PSBBN301W	PS530P5WR	PS530C5WR	PS530R5WL	PS530C5WL	

APPLICATION SPECIFIC

\*Reference page J-2.



PS330C4WR

PS330P4WR

Ordering Information

# Pin & Sleeve Devices North American Watertight Devices Ordering Information

## North American Product Offering

<b>IP67</b> Suitability				Watertight				Back Boxes		Replacement Parts			
Configuration				Receptacle†	Plug	Connector	Inlet	Metallic Back Box	Non-Metallic Back Box	Bodies		Caps	
Poles & Wires	Recep./ Conn.	Plug/ Inlet	Voltage/ Color Coding							Plug	Connector	Receptacle	Connector
<b>60 Amps</b>													
2P3W			125	PS360R4W	PS360P4W	PS360C4W	PS360B4W	PSBB601W	PSBBN601W	PS360P4WR	PS360C4WR	PS360R4WL	PS360C4WL
2P3W			250	PS360R6W	PS360P6W	PS360C6W	PS360B6W	PSBB601W	PSBBN601W	PS360P6WR	PS360C6WR	PS360R6WL	PS360C6WL
2P3W			480	PS360R7W	PS360P7W	PS360C7W	PS360B7W	PSBB601W	PSBBN601W	PS360P7WR	PS360C7WR	PS360R7WL	PS360C7WL
3P4W			125/250	PS460R12W	PS460P12W	PS460C12W	PS460B12W	PSBB601W	PSBBN601W	PS460P12WR	PS460C12WR	PS460R12WL	PS460C12WL
3P4W			3ø 250	PS460R9W	PS460P9W	PS460C9W	PS460B9W	PSBB601W	PSBBN601W	PS460P9WR	PS460C9WR	PS460R9WL	PS460C9WL
3P4W			3ø 480	PS460R7W	PS460P7W	PS460C7W	PS460B7W	PSBB601W	PSBBN601W	PS460P7WR	PS460C7WR	PS460R7WL	PS460C7WL
3P4W			3ø 600	PS460R5W	PS460P5W	PS460C5W	PS460B5W	PSBB601W	PSBBN601W	PS460P5WR	PS460C5WR	PS460R5WL	PS460C5WL
4P5W			3øY 120/208	PS560R9W	PS560P9W	PS560C9W	PS560B9W	PSBB601W	PSBBN601W	PS560P9WR	PS560C9WR	PS560R9WL	PS560C9WL
4P5W			3øY 277/480	PS560R7W	PS560P7W	PS560C7W	PS560B7W	PSBB601W	PSBBN601W	PS560P7WR	PS560C7WR	PS560R7WL	PS560C7WL
4P5W			3øY 347/600	PS560R5W	PS560P5W	PS560C5W	PS560B5W	PSBB601W	PSBBN601W	PS560P5WR	PS560C5WR	PS560R5WL	PS560C5WL
<b>100 Amps</b>													
2P3W			125	PS3100R4W	PS3100P4W	PS3100C4W	PS3100B4W	PSBB1001W		PS3100P4WR	PS3100C4WR	PS3100R4WL	PS3100C4WL
2P3W			250	PS3100R6W	PS3100P6W	PS3100C6W	PS3100B6W	PSBB1001W		PS3100P6WR	PS3100C6WR	PS3100R6WL	PS3100C6WL
2P3W			480	PS3100R7W	PS3100P7W	PS3100C7W	PS3100B7W	PSBB1001W		PS3100P7WR	PS3100C7WR	PS3100R7WL	PS3100C7WL
3P4W			125/250	PS4100R12W	PS4100P12W	PS4100C12W	PS4100B12W	PSBB1001W		PS4100P12WR	PS4100C12WR	PS4100R12WL	PS4100C12WL
3P4W			3ø 250	PS4100R9W	PS4100P9W	PS4100C9W	PS4100B9W	PSBB1001W		PS4100P9WR	PS4100C9WR	PS4100R9WL	PS4100C9WL
3P4W			3ø 480	PS4100R7W	PS4100P7W	PS4100C7W	PS4100B7W	PSBB1001W		PS4100P7WR	PS4100C7WR	PS4100R7WL	PS4100C7WL
3P4W			3ø 600	PS4100R5W	PS4100P5W	PS4100C5W	PS4100B5W	PSBB1001W		PS4100P5WR	PS4100C5WR	PS4100R5WL	PS4100C5WL
4P5W			3øY 120/208	PS5100R9W	PS5100P9W	PS5100C9W	PS5100B9W	PSBB1001W		PS5100P9WR	PS5100C9WR	PS5100R9WL	PS5100C9WL
4P5W			3øY 277/480	PS5100R7W	PS5100P7W	PS5100C7W	PS5100B7W	PSBB1001W		PS5100P7WR	PS5100C7WR	PS5100R7WL	PS5100C7WL
4P5W			3øY 347/600	PS5100R5W	PS5100P5W	PS5100C5W	PS5100B5W	PSBB1001W		PS5100P5WR	PS5100C5WR	PS5100R5WL	PS5100C5WL

† Note: For straight 60 and 100 amp watertight receptacles, consult factory.

# Pin & Sleeve Devices North American Splashproof Devices Ordering Information

Pass & Seymour



IEC Pin & Sleeve Splashproof Devices

Ordering Information

## North American Product Offering

<b>IP44</b> Suitability				<b>Splashproof</b>				<b>Back Boxes</b>		<b>Non-Metallic Back Box</b>
<b>Configuration</b>										
<b>Poles &amp; Wires</b>	<b>Recep./ Conn.</b>	<b>Plug/ Inlet</b>	<b>Voltage/ Color Coding</b>	<b>Receptacle</b>	<b>Plug</b>	<b>Connector</b>	<b>Inlet</b>	<b>Angled Box Receptacle</b>	<b>Inlet</b>	<b>Receptacle</b>
<b>20 Amps</b>										
2P3W			125	PS320R4S	PS320P4S	PS320C4S	PS320B4S	PSBB201W	PSBB201SP	PSBBN201W
2P3W			250	PS320R6S	PS320P6S	PS320C6S	PS320B6S	PSBB201W	PSBB201SP	PSBBN201W
2P3W			480	PS320R7S	PS320P7S	PS320C7S	PS320B7S	PSBB201W	PSBB201SP	PSBBN201W
2P3W			277	PS320R5S	PS320P5S	PS320C5S	PS320B5S	PSBB201W	PSBB201SP	PSBBN201W
3P4W			125/250	PS420R12S	PS420P12S	PS420C12S	PS420B12S	PSBB202W	PSBB201SP	PSBBN202W
3P4W			3ø 250	PS420R9S	PS420P9S	PS420C9S	PS420B9S	PSBB202W	PSBB201SP	PSBBN202W
3P4W			3ø 480	PS420R7S	PS420P7S	PS420C7S	PS420B7S	PSBB202W	PSBB201SP	PSBBN202W
3P4W			3ø 600	PS420R5S	PS420P5S	PS420C5S	PS420B5S	PSBB202W	PSBB201SP	PSBBN202W
4P5W			3øY 120/208	PS520R9S	PS520P9S	PS520C9S	PS520B9S	PSBB202W	PSBB201SP	PSBBN202W
4P5W			3øY 277/480	PS520R7S	PS520P7S	PS520C7S	PS520B7S	PSBB202W	PSBB201SP	PSBBN202W
4P5W			3øY 347/600	PS520R5S	PS520P5S	PS520C5S	PS520B5S	PSBB202W	PSBB201SP	PSBBN202W
<b>30 Amps</b>										
2P3W			125	PS330R4S	PS330P4S	PS330C4S	PS330B4S	PSBB301W	PSBB301SP	PSBBN301W
2P3W			250	PS330R6S	PS330P6S	PS330C6S	PS330B6S	PSBB301W	PSBB301SP	PSBBN301W
2P3W			480	PS330R7S	PS330P7S	PS330C7S	PS330B7S	PSBB301W	PSBB301SP	PSBBN301W
3P4W			125/250	PS430R12S	PS430P12S	PS430C12S	PS430B12S	PSBB301W	PSBB301SP	PSBBN301W
3P4W			3ø 250	PS430R9S	PS430P9S	PS430C9S	PS430B9S	PSBB301W	PSBB301SP	PSBBN301W
3P4W			3ø 480	PS430R7S	PS430P7S	PS430C7S	PS430B7S	PSBB301W	PSBB301SP	PSBBN301W
3P4W			3ø 600	PS430R5S	PS430P5S	PS430C5S	PS430B5S	PSBB301W	PSBB301SP	PSBBN301W
4P5W			3øY 120/208	PS530R9S	PS530P9S	PS530C9S	PS530B9S	PSBB301W	PSBB301SP	PSBBN301W
4P5W			3øY 277/480	PS530R7S	PS530P7S	PS530C7S	PS530B7S	PSBB301W	PSBB301SP	PSBBN301W
4P5W			3øY 347/600	PS530R5S	PS530P5S	PS530C5S	PS530B5S	PSBB301W	PSBB301SP	PSBBN301W
<b>60 Amps</b>										
2P3W			125	PS360R4S	PS360P4S	PS360C4S	PS360B4S	PSBB601W	PSBB601W	PSBBN601W
2P3W			250	PS360R6S	PS360P6S	PS360C6S	PS360B6S	PSBB601W	PSBB601W	PSBBN601W
2P3W			480	PS360R7S	PS360P7S	PS360C7S	PS360B7S	PSBB601W	PSBB601W	PSBBN601W
3P4W			125/250	PS460R12S	PS460P12S	PS460C12S	PS460B12S	PSBB601W	PSBB601W	PSBBN601W
3P4W			3ø 250	PS460R9S	PS460P9S	PS460C9S	PS460B9S	PSBB601W	PSBB601W	PSBBN601W
3P4W			3ø 480	PS460R7S	PS460P7S	PS460C7S	PS460B7S	PSBB601W	PSBB601W	PSBBN601W
3P4W			3ø 600	PS460R5S	PS460P5S	PS460C5S	PS460B5S	PSBB601W	PSBB601W	PSBBN601W
4P5W			3øY 120/208	PS560R9S	PS560P9S	PS560C9S	PS560B9S	PSBB601W	PSBB601W	PSBBN601W
4P5W			3øY 277/480	PS560R7S	PS560P7S	PS560C7S	PS560B7S	PSBB601W	PSBB601W	PSBBN601W
4P5W			3øY 347/600	PS560R5S	PS560P5S	PS560C5S	PS560B5S	PSBB601W	PSBB601W	PSBBN601W

\* Line art for 60 amp only. 20 and 30 amp inlets are angled.  
\*\* Line art for 20 and 30 amp only. 60 amp back box is angled.

# Pin & Sleeve Devices International Watertight & Splashproof Devices Ordering Information

## International Product Offering

				Watertight (IP67 Suitability)						Splashproof (IP44 Suitability)					
Poles & Wires	Configuration		Voltage/Color Coding												
	Recep./Conn.	Plug/Inlet		Surface Receptacle	Receptacle	Plug	Connector	Inlet	Non-Metallic Back Box	Surface Receptacle	Receptacle	Plug	Connector	Inlet	Non-Metallic Back Box
<b>16 Amps</b>															
2P3W			110/120	51925	51925	51955	51985		52029	51920	51920	51940	51980	51970*	52029
2P3W			220/240	51126	51126	52046	52086		52029	52022	52022	52042	52082	52172*	52029
2P3W			380/415							52222	52222	52242	52282	52272*	52029
3P4W			220/240							52023	52023	52043	52083	52073*	52229
3P4W			380/415	52227	52227	52247	52287		52229	52223	52223	52243	52283	52173*	52229
3P4W			440							52310	52310	52311	52312		52229
3P4W			500							52320	52320	52321	52322		52229
4P5W			220/240							52024	52024*	52044	52084	52074*	52229
4P5W			220/380 240/415	51131	51131	51161	51181		52229	52224	52224	52244	52284	52174	52229
<b>32 Amps</b>															
2P3W			110/120	51926	51926	51946	51986							51972*	
2P3W			220/240	52726	52726	52746	52786			52722	52722	52742	52782	52872*	
2P3W			380/415							52922	52922	52942	52982	52972*	
3P4W			220/240							52723	52723	52743	52783	52773*	
3P4W			380/415	52927	52927	52947	52987			52923	52923	52943	52983	52873*	
3P4W			440							52350	52350	52351	52352		
3P4W			500							52360	52360	52361	52362		
4P5W			220/240							52724	52724	52744	52784	52774*	
4P5W			220/380 240/415	52928	52928	52948	52988			52924	52924	52944	52984	52874*	
<b>63 Amps</b>															
2P3W			110/120							53522	53542**	53582			53889
2P3W			220/240	53636**	53626	53646	53686		53889	53722	53622**	53642	53682	53772*	53889
3P4W			220/240	53637**	53627	53647	53687		53889	53633	53623**	53643	53683		53889
3P4W			380/415	53837**	53827	53847	53887		53889	53723	53823**	53843	53883	53773*	53889
3P4W			500	53737**	53727	53747	53787		53889						53889
4P5W			220/240	53638**	53628	53648	53688		53889	53634	53624**	53644	53684		53889
4P5W			220/380 240/415	53838**	53828	53848	53888		53889	53724	53824**	53844	53884	53774*	53889
<b>125 Amps</b>															
3P4W			380/415	59102**	59112	59122	59132	59142							
4P5W			220/380 240/0/41	59103**	59113	59123	59133	59143							

\*Use with Back Box listed for surface mounting. Refer to chart on J-31.

\*\*Complete unit sold with receptacle and surface mount box.



















Additional international configuration available — consult Factory Export Department.

# Pin & Sleeve Devices Special Voltages & Frequencies

Pass & Seymour



## Special Voltages and Frequencies

<b>IP44</b> Suitability				Splashproof				
								Surface Receptacle
Poles & Wires	Recep./ Conn.	Plug/ Inlet	Voltage/ Color-Coding					
<b>16 Amps</b>								
2P			24V				52421	
2P			42VDC					
3P			24V	52402*	52402			
3P4W			50-500V 100/300Hz					
<b>32 Amps</b>								
2P			24V					
2P			42V					
3P4W			50-500V 100/300Hz				52371	

\* Use with Back Box listed below for surface mounting.

Additional international configuration available—consult Factory Export Department.

Size	
<b>Back Box for IP67 &amp; IP44 Non-Metallic Inlets and Receptacles</b>	
16A: 2P3W	52079
16A: 3P4W, 4P5W	52279
63A: All	53879

Device Type	Adapter Plate Leviton, Crouse Hinds/Appleton	Device Type	Adapter Plate Hubbell
<b>Competitor Back Box Adapter Plate</b>			
20A 3 Wire	PSAP320CA	20A 3 Wire	PSAP320HBL
20A 4, 5 Wire	PSAP4520CA	20A 4 Wire	PSAP420HBL
All 30A	PSAP30CA	20A 5 Wire & All 30A	PSAP52030HBL
All 60A		All 60A	PSAP60HB

Pass &amp; Seymour



# Pin & Sleeve Devices Watertight Dimensional Information

## 16/20 & 30/32 Amp Watertight Devices/Dimensional Information

Amps	Wire Configurations	A	B	C	D	E	F
<b>Watertight Receptacles</b>							
16/20	2 Pole, 3 Wire	2.85	1.80	1.60	3.40	2.05	2.36
	3 Pole, 4 Wire	3.20	1.90	1.60	3.80	2.36	2.75
	4 Pole, 5 Wire	3.40	2.00	1.70	3.80	2.36	2.75
30/32	2 Pole, 3 Wire	3.72	2.60	1.80	4.30	2.75	3.15
	3 Pole, 4 Wire	3.72	2.60	1.90	4.30	2.75	3.15
	4 Pole, 5 Wire	3.98	2.70	1.95	4.30	2.75	3.15
<b>Watertight Plugs</b>							
16/20	2 Pole, 3 Wire	5.30	2.85		.31-.59		
	3 Pole, 4 Wire	5.50	3.20		.31-.59		
	4 Pole, 5 Wire	6.00	3.40		.39-.71		
30/32	2 Pole, 3 Wire	6.50	3.70		.39-.71		
	3 Pole, 4 Wire	6.50	3.70		.47-.87		
	4 Pole, 5 Wire	6.70	3.98		.47-.87		
<b>Watertight Connectors</b>							
16/20	2 Pole, 3 Wire	5.90	2.85	3.00	.31-.59		
	3 Pole, 4 Wire	6.00	3.20	3.40	.31-.59		
	4 Pole, 5 Wire	6.70	3.40	3.50	.39-.71		
30/32	2 Pole, 3 Wire	7.00	3.70	3.90	.39-.71		
	3 Pole, 4 Wire	7.00	3.70	3.90	.47-.87		
	4 Pole, 5 Wire	7.30	3.98	4.10	.47-.87		

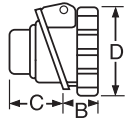

Receptacles

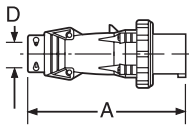

Plugs

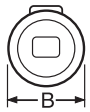
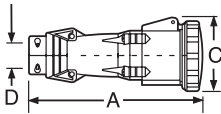

Connectors

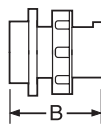
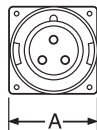

Inlets

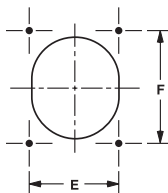
Receptacle/Inlet  
Drilling Pattern

## 60/63 Amp Watertight Devices/Dimensional Information

Amps	Wire Configurations	A	B	C	D	E	F
<b>Watertight Receptacles</b>							
60/63	2 Pole, 3 Wire	4.20	3.10	3.50	5.00	3.03	3.35
	3 Pole, 4 Wire	4.20	3.10	3.50	5.00	3.03	3.35
	4 Pole, 5 Wire	4.20	3.10	3.50	5.00	3.03	3.35
<b>Watertight Plugs</b>							
60/63	2 Pole, 3 Wire	10.00	4.50		.63-1.04		
	3 Pole, 4 Wire	10.00	4.50		.73-1.14		
	4 Pole, 5 Wire	10.00	4.50		.80-1.26		
<b>Watertight Connectors</b>							
60/63	2 Pole, 3 Wire	10.90	4.50	4.70	.63-1.04		
	3 Pole, 4 Wire	10.90	4.50	4.70	.73-1.14		
	4 Pole, 5 Wire	10.90	4.50	4.70	.80-1.26		
<b>Watertight Inlets</b>							
60/63	2 Pole, 3 Wire	4.50	4.25			3.03	3.35
	3 Pole, 4 Wire	4.50	4.25			3.03	3.35
	4 Pole, 5 Wire	4.50	4.25			3.03	3.35

## 100/125 Amp Watertight Devices/Dimensional Information

Amps	Wire Configurations	A	B	C	D	E	F
<b>Watertight Receptacles</b>							
100/125	2 Pole, 3 Wire	5.20	2.20	4.40	5.60	4.88	4.88
	3 Pole, 4 Wire	5.20	2.20	4.40	5.60	4.88	4.88
	4 Pole, 5 Wire	5.20	2.20	4.40	5.60	4.88	4.88
<b>Watertight Plugs</b>							
100/125	2 Pole, 3 Wire	13.40	5.20		.59-1.97		
	3 Pole, 4 Wire	13.40	5.20		.59-1.97		
	4 Pole, 5 Wire	13.40	5.20		.59-1.97		
<b>Watertight Connectors</b>							
100/125	2 Pole, 3 Wire	14.30	5.20	5.30	.59-1.97		
	3 Pole, 4 Wire	14.30	5.20	5.30	.59-1.97		
	4 Pole, 5 Wire	14.30	5.20	5.30	.59-1.97		
<b>Watertight Inlets</b>							
100/125	2 Pole, 3 Wire	5.75	5.71			4.88	4.88
	3 Pole, 4 Wire	5.75	5.71			4.88	4.88
	4 Pole, 5 Wire	5.75	5.71			4.88	4.88

All measurements shown in inches.

# Pin & Sleeve Devices Splashproof Dimensional Information

Pass & Seymour



IEC Pin & Sleeve Devices

## 16/20 & 30/32 Amp Splashproof Devices/Dimensional Information

Amps	Wire Configurations	A	B	C	D	E	F
<b>Splashproof Receptacles</b>							
16/20	2 Pole, 3 Wire	2.50	1.57	1.60	3.10	2.05	2.36
	3 Pole, 4 Wire	2.90	1.57	1.73	3.46	2.36	2.75
	4 Pole, 5 Wire	2.90	1.73	1.73	3.66	2.36	2.75
30/32	2 Pole, 3 Wire	3.30	2.10	1.97	4.06	2.75	3.15
	3 Pole, 4 Wire	3.30	2.10	1.97	4.06	2.75	3.15
	4 Pole, 5 Wire	3.30	2.20	2.05	4.20	2.75	3.15
<b>Splashproof Plugs</b>							
16/20	2 Pole, 3 Wire	5.30	2.17		.31-.59		
	3 Pole, 4 Wire	5.50	2.36		.31-.59		
	4 Pole, 5 Wire	6.00	2.60		.39-.71		
30/32	2 Pole, 3 Wire	6.50	2.78		.39-.71		
	3 Pole, 4 Wire	6.50	2.78		.47-.87		
	4 Pole, 5 Wire	6.70	3.03		.47-.87		
<b>Splashproof Connectors</b>							
16/20	2 Pole, 3 Wire	5.79	2.15	2.91	.31-.59		
	3 Pole, 4 Wire	5.94	2.42	3.19	.31-.59		
	4 Pole, 5 Wire	6.77	2.73	3.54	.39-.71		
30/32	2 Pole, 3 Wire	6.97	2.80	3.66	.39-.71		
	3 Pole, 4 Wire	6.97	2.80	3.66	.47-.87		
	4 Pole, 5 Wire	7.20	3.05	3.94	.47-.87		
<b>Splashproof Inlets</b>							
16/20	2 Pole, 3 Wire	2.83	3.07			2.44	3.70
	3 Pole, 4 Wire	3.70	3.39			3.27	4.29
	4 Pole, 5 Wire	3.70	3.39			3.27	4.29
30/32	2 Pole, 3 Wire	3.98	4.37			3.54	5.86
	3 Pole, 4 Wire	3.98	4.37			3.54	5.86
	4 Pole, 5 Wire	3.98	4.25			3.54	5.86

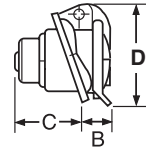
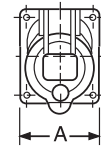

Receptacles

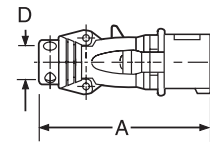

Plugs

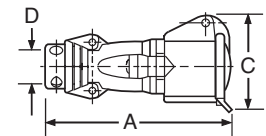

Connectors

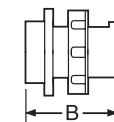
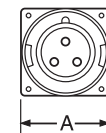

Inlets

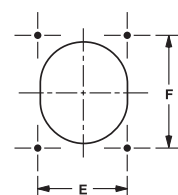

Receptacle/Inlet  
Drilling Pattern

## 60/63 Amp Splashproof Devices/Dimensional Information

Amps	Wire Configurations	A	B	C	D	E	F
<b>Splashproof Receptacles</b>							
60/63	2 Pole, 3 Wire	4.20	3.50	2.76	5.08	3.03	3.35
	3 Pole, 4 Wire	4.20	3.50	2.76	5.08	3.03	3.35
	4 Pole, 5 Wire	4.20	3.50	2.76	5.08	3.03	3.35
<b>Splashproof Plugs</b>							
60/63	2 Pole, 3 Wire	10.00	4.02		.63-1.04		
	3 Pole, 4 Wire	10.00	4.02		.73-1.14		
	4 Pole, 5 Wire	10.00	4.02		.80-1.26		
<b>Splashproof Connectors</b>							
60/63	2 Pole, 3 Wire	10.75	3.78	4.67	.63-1.04		
	3 Pole, 4 Wire	10.75	3.78	4.67	.73-1.14		
	4 Pole, 5 Wire	10.75	3.78	4.67	.80-1.26		
<b>Splashproof Inlets</b>							
60/63	2 Pole, 3 Wire	4.50	4.25			3.03	3.35
	3 Pole, 4 Wire	4.50	4.25			3.03	3.35
	4 Pole, 5 Wire	4.50	4.25			3.03	3.35

All measurements shown in inches.

Splashproof Dimensional Information

# Pin & Sleeve Devices

## Watertight & Splashproof Material & Performance

### Pin & Sleeve Product Specifications

	16/20 Amp	30/32 Amp	60/63 Amp	100/125 Amp
<b>Receptacles</b>				
Housing	Polyamide 6	Polyamide 6	Valox	Valox
Cover	Polyamide 66	Polyamide 66	Valox	Valox
Cover Spring	Stainless Steel	Stainless Steel	Stainless Steel	Stainless Steel
Sealing Gasket†	Neoprene	Neoprene	Neoprene	Neoprene
Mounting Gasket	Neoprene	Neoprene	Neoprene	Neoprene
Contact Carrier	Polyamide 6	Polyamide 6	Polyamide 6	Polyamide 6
Sleeves	Brass w/Nickel Plate*†	Brass w/Nickel Plate*†	Brass w/Nickel Plate	Brass w/Nickel Plate
Terminal Screws	Zinc-Plated Steel	Zinc-Plated Steel	Zinc-Plated Steel	Zinc-Plated Steel
<b>Inlets</b>				
Housing	Polyamide 6	Polyamide 6	Valox	Valox
Mounting Flange	Polyamide 6	Polyamide 6	Valox	Valox
Locking Ring*†	Polyamide 66	Polyamide 66	Valox	Valox
Sealing Gasket†	Neoprene	Neoprene	Neoprene	Neoprene
Mounting Gasket	Neoprene	Neoprene	Neoprene	Neoprene
Contact Carrier	Polyamide 6	Polyamide 6	Polyamide 6	Polyamide 6
Pins	Brass w/Nickel Plate*†	Brass w/Nickel Plate*†	Brass w/Nickel Plate	Brass w/Nickel Plate
Terminal Screws	Zinc-Plated Steel	Zinc-Plated Steel	Zinc-Plated Steel	Zinc-Plated Steel
<b>Plugs</b>				
Housing	Polyamide 6	Polyamide 6	Valox	Valox
Locking Ring*†	Polyamide 66	Polyamide 66	Valox	Valox
Sealing Gasket†	Neoprene	Neoprene	Neoprene	Neoprene
Housing Gasket	Neoprene	Neoprene	Neoprene	Neoprene
Back Body	Polyamide 6	Polyamide 6	Valox	Valox
Contact Carrier	Polyamide 6	Polyamide 6	Polyamide 6	Polyamide 6
Pins	Brass w/Nickel Plate*†	Brass w/Nickel Plate*†	Brass w/Nickel Plate	Brass w/Nickel Plate
Terminal Screws	Zinc-Plated Steel	Zinc-Plated Steel	Zinc-Plated Steel	Zinc-Plated Steel
Cord Grip	Polyamide 6	Polyamide 6	Polyamide 66	Polyamide 66
Grommet	Natural Rubber	Natural Rubber	Natural Rubber	Natural Rubber
Cord Grip Screws	Stainless Steel	Stainless Steel	Stainless Steel	Stainless Steel
Assembly Screws	Stainless Steel	Stainless Steel	Stainless Steel	Stainless Steel
<b>Connectors</b>				
Housing	Polyamide 6	Polyamide 6	Valox	Valox
Cover	Polyamide 66	Polyamide 66	Valox	Valox
Cover Spring	Stainless Steel	Stainless Steel	Stainless Steel	Stainless Steel
Sealing Gasket†	Neoprene	Neoprene	Neoprene	Neoprene
Housing Gasket	Neoprene	Neoprene	Neoprene	Neoprene
Back Body	Polyamide 6	Polyamide 6	Valox	Valox
Contact Carrier	Polyamide 6	Polyamide 6	Polyamide 6	Polyamide 6
Sleeves	Brass w/Nickel Plate*†	Brass w/Nickel Plate*†	Brass w/Nickel Plate	Brass w/Nickel Plate
Terminal Screws	Zinc-Plated Steel	Zinc-Plated Steel	Zinc-Plated Steel	Zinc-Plated Steel
Cord Grip	Polyamide 6	Polyamide 6	Polyamide 66	Polyamide 66
Grommet	Natural Rubber	Natural Rubber	Natural Rubber	Natural Rubber
Cord Grip Screws	Stainless Steel	Stainless Steel	Stainless Steel	Stainless Steel
Assembly Screws	Stainless Steel	Stainless Steel	Stainless Steel	Stainless Steel
<b>Metallic Back Box</b>				
Housing	Cast Aluminum			
Hub	Cast Iron			
<b>Non-Metallic Back Box</b>				
Housing	Polyamide 6			
Hub				

† Does not apply to splashproof.

\* 16/20A and 30/32A sleeves and pins on splashproof products are brass only. Splashproof inlets and plugs do not have locking rings.

Consult factory for additional details.

### Performance

#### Electrical:

Dielectric Voltage Withstand	3000V maximum
Maximum Working Voltage	600 RMS
Current Interrupting	Certified for current interrupting at full-rated current
Temperature Rise	Maximum 30°C temperature rise at full-rated current after 50 cycles of 150% overload (at 0.75 to 0.80 power factor)
Endurance	20 amp: 5000 cycles with full-rated current and voltage  30, 60, 100 amp: 2000 cycles with full-rated current and voltage applied on every other cycle

#### Mechanical:

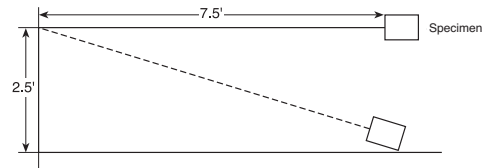

Impact Resistance Device dropped 8 times from a height of 2.5 feet with 7.5 feet of cord attached (per CSA 182.1)

#### Cord Grip Retention

	Force, Lbs.**	Torque, Ft.lbs.**
20A	30	0.4
30A	75	0.5
60A	150	1.0
100A	150	1.0

\*\*Applied to minimum recommended cable size.

Cord Accommodation	Round portable service cords  Diameters commensurate with the device rating as defined in UL62, CSA C22.2, No. 49, and the harmonized (HAR) European Standard
Terminal Identification	Identified in accordance with North American convention, UL1682, and IEC 309-1, 309-2
Product Identification	Identification and ratings are labeled on the device housing

#### Environmental:

Moisture Resistance	Per IEC 309-1
Flammability	Contact with live parts: V2 or V0 Enclosure: HB or better per UL94
Operating Temperature	+80°C maximum continuous; -50°C minimum without impact

# Pin & Sleeve Devices Accessories/Dimensional Information

Pass & Seymour



## Metallic Back Boxes Dimensions

Catalog Number	A	B	C	D	E	F	G	H	J DIA	K	L
PSBB201W	5.60	5.00	3.17	5.00	2.05	2.36	8-32UNC	2.04	.20 DIA	1/2" NPT	2.75
PSBB202W	6.82	6.12	4.11	6.07	2.36	2.76	8-32UNC	2.55	.20 DIA	3/4" NPT	3.61
PSBB201SP	7.00	5.98	2.00	6.00	3.27	4.29	8-32UNC	3.00	.20 DIA	3/4" NPT	3.96
PSBB301W	6.82	6.12	4.11	6.07	2.76	3.15	8-32UNC	2.55	.20 DIA	3/4" NPT	3.61
PSBB301SP	8.60	7.58	2.00	7.60	3.54	5.87	8-32UNC	3.00	.20 DIA	3/4" NPT	4.22
PSBB601W	8.63	7.75	4.92	7.70	3.03	3.35	10-24UNC	3.87	.28 DIA	1 1/2" NPT	4.75
PSBB1001W	12.50	11.00	6.25	11.00	4.88	4.88	1/4-20UNC	4.75	.28 DIA	1 1/2" NPT	6.25
PSBB1002W	12.50	11.00	6.25	11.00	4.88	4.88	1/4-20UNC	4.75	.28 DIA	2" NPT	6.25

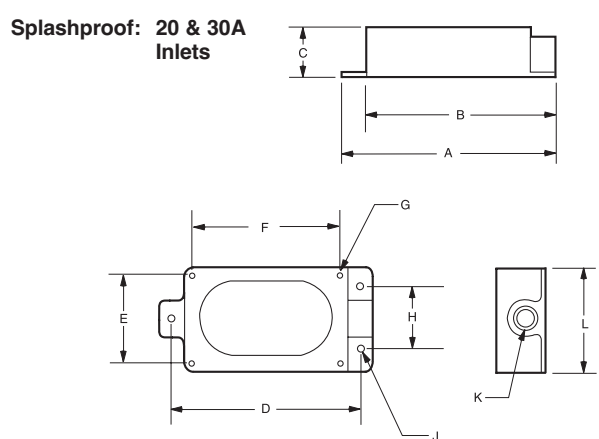
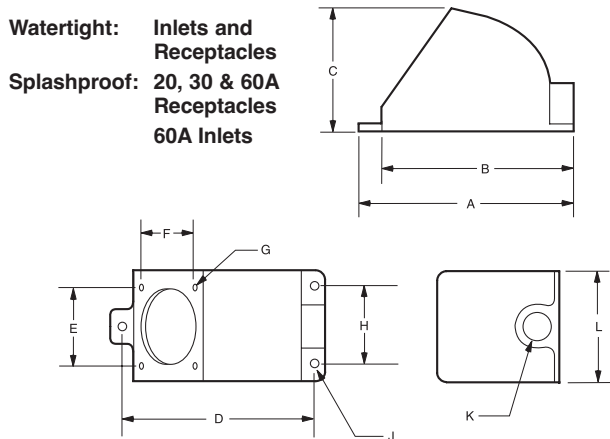

## Non-Metallic Back Boxes Dimensions

Catalog Number	A	B	C	D	E	Hub Size
PSBBN201W	2.50	2.31	4.16	2.28	0.78	3/4" NPT
PSBBN202W	3.34	3.78	4.81	2.38	0.63	3/4" NPT
PSBBN301W	3.53	4.03	6.38	3.53	1.03	1" NPT
PSBBN601W	6.00	6.69	11.81	5.91	1.56	1 1/2" NPT

All measurements shown in inches.

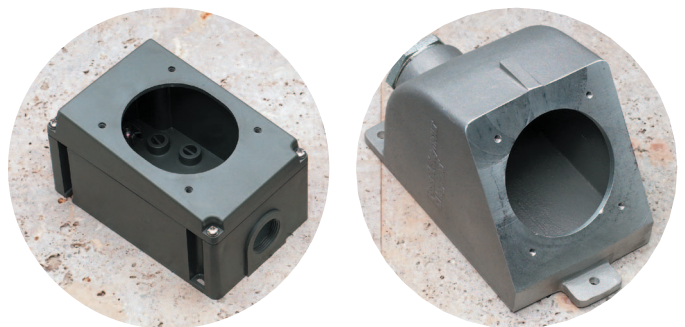

In both non-metallic (left) and metallic (right) Back Boxes, you'll find easy installation and no-compromises durability.

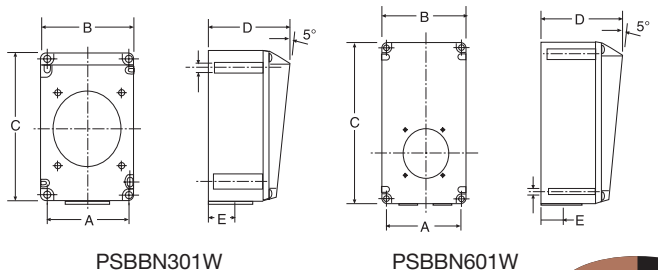
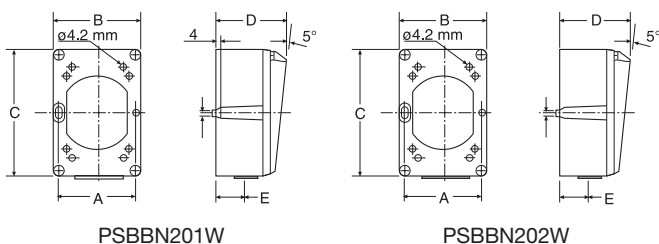

PSBBN201W

PSBBN202W

PSBBN301W

PSBBN601W

# Pin & Sleeve Devices Accessories/Dimensional Information

## Pin & Sleeve Strain Relief Adapters

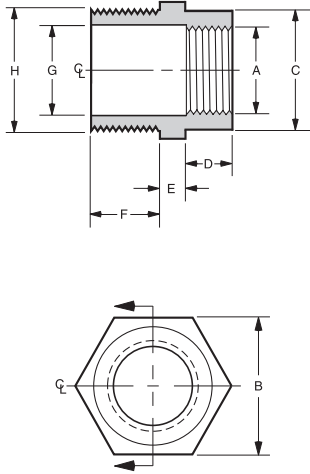

Catalog Number	A	B	C	D	E	F	G	H (Metric Thread)
PSAD2050	1/2" NPT	1.38	1.13	.54	.25	.47	.75	M25X1.5
PSAD2034	3/4" NPT	1.50	1.50	.56	.25	.47	.75	M25X1.5
PSAD3050	1/2" NPT	1.38	1.13	.54	.25	.47	.88	M32X1.5
PSAD3034	3/4" NPT	1.50	1.50	.56	.25	.47	.88	M32X1.5
PSAD301	1" NPT	1.75	1.75	.70	.25	.47	.88	M32X1.5
PSAD601	1" NPT	2.00	1.75	.70	.38	1.00	1.38	M45X2
PSAD60125	1 1/4" NPT	2.00	2.00	.70	.38	1.00	1.38	M45X2
PSAD60150	1 1/2" NPT	2.38	2.38	.70	.38	1.00	1.38	M45X2
PSAD100125	1 1/4" NPT	2.50	2.38	.70	.38	1.10	2.00	M60X2
PSAD100150	1 1/2" NPT	2.50	2.38	.70	.38	1.10	2.00	M60X2
PSAD1002	2" NPT	2.75	2.70	.75	.38	1.10	2.00	M60X2

All measurements shown in inches.



PSCP320



PSCP60



Choose from a full range of P&S Strain Relief Adapters, all built extra-tough for no-worries dependability.

## Back Box & Protective Covers

Device Type	Back Box	Hub Size	Protective Plug & Inlet Cover
20A 3 Wire	PSBB201W	1/2"	PSCP320
20A 4 Wire	PSBB202W	3/4"	PSCP420
20A 5 Wire	PSBB202W	3/4"	PSCP520
20A 3, 4, 5 Wire (Inlet)	PSBB201SP	3/4"	
30A 3, 4 Wire	PSBB301W	3/4"	PSCP3430
30A 5 Wire	PSBB301W	3/4"	PSCP530
30A 3, 4, 5 Wire (Inlet)	PSBB301SP	3/4"	
All 60A	PSBB601W*	1 1/2"	PSCP60
All 100A	PSBB1001W	1 1/2"	PSCP100
All 100A	PSBB1002W	2"	

\*1 1/4" Reducer Supplied

## Strain Relief Adapter Fittings

Device Type	Fitting Size	Catalog Number
20A 3, 4 Wire	1/2" NPT	PSAD2050
20A 3, 4 Wire	3/4" NPT	PSAD2034
20A 5W, All 30A	1/2" NPT	PSAD3050
30A 3, 4 Wire	3/4" NPT	PSAD3034
30A 3, 4 Wire	1" NPT	PSAD301
All 60A	1" NPT	PSAD601
All 60A	1 1/4" NPT	PSAD60125
All 60A	1 1/2" NPT	PSAD60150
All 100A	1 1/4" NPT	PSAD100125
All 100A	1 1/2" NPT	PSAD100150
All 100A	2" NPT	PSAD1002

# Pin & Sleeve Devices Technical Specifications

Pass & Seymour



## Watertight Pin & Sleeve Plugs

20, 30, 60 & 100A

### Typical Specifications

Manufacturer's Identification: Pass & Seymour/Legrand PS460P7-W

Description: Plug, Power Supply

Type: 3 Pole, 4 Wire Grounding

Rating: 60A, 3 Phase 480VAC

Configuration: IEC 309-2, Clock Position 7, Watertight (IP67)

3rd Party Compliance: UL Listed to UL Standard 1682; CSA Certified to CSA 22.2 No. 182.2; UL Classified to IEC 309-1 and IEC 309-2

## Watertight Pin & Sleeve Connectors

20, 30, 60 & 100A

### Typical Specifications

Manufacturer's Identification: Pass & Seymour/Legrand PS460C7-W

Description: Connector, Power Supply

Type: 3 Pole, 4 Wire Grounding

Rating: 60A, 3 Phase 480VAC

Configuration: IEC 309-2, Clock Position 7, Watertight (IP67)

3rd Party Compliance: UL Listed to UL Standard 1682; CSA Certified to CSA 22.2 No. 182.2; UL Classified to IEC 309-1 and IEC 309-2

## Splashproof Pin & Sleeve Plugs

20, 30 & 60A

### Typical Specifications

Manufacturer's Identification: Pass & Seymour/Legrand PS460P7-S

Description: Plug, Power Supply

Type: 3 Pole, 4 Wire Grounding

Rating: 60A, 3 Phase 480VAC

Configuration: IEC 309-2, Clock Position 7, Splashproof (IP44)

3rd Party Compliance: UL Listed to UL Standard 1682; CSA Certified to CSA 22.2 No. 182.2; UL Classified to IEC 309-1 and IEC 309-2

## Splashproof Pin & Sleeve Connectors

20, 30 & 60A

### Typical Specifications

Manufacturer's Identification: Pass & Seymour/Legrand PS460C7-S

Description: Connector, Power Supply

Type: 3 Pole, 4 Wire Grounding

Rating: 60A, 3 Phase 480VAC

Configuration: IEC 309-2, Clock Position 7, Splashproof (IP44)

3rd Party Compliance: UL Listed to UL Standard 1682; CSA Certified to CSA 22.2 No. 182.2; UL Classified to IEC 309-1 and IEC 309-2

### IP Suitability Rating

IP Suitability Ratings are an international system for classifying the degree of protection provided by enclosures of electrical equipment. The higher the number, the greater the degree of protection; they apply ONLY to properly installed equipment. The numerals stand for the following:

1. First Number: Degree of protection for persons against access to hazardous parts inside the enclosure and/or against solid bodies.
2. Second Number: Degree of protection of equipment inside enclosures against damage from the ingress of water.

IEC Enclosure Classification Designation		
Code Letters	First Number	Second Number
Ingress Protection	Against Ingress of Solid Bodies	Against Ingress of Water with Harmful Effects
IP	0 - Nonprotected 1 - $\geq$ 50 mm diameter 2 - $\geq$ 12.5 mm diameter 3 - $\geq$ 2.5 mm diameter 4 - $\geq$ 1.0 mm 5 - Dust-protected 6 - Dusttight	0 - Nonprotected 1 - Vertically dripping 2 - Dripping (15° Tilted) 3 - Spraying 4 - Splashing 5 - Jetting 6 - Power jetting 7 - Temporary immersion 8 - Continuous immersion

**Note:**  $\geq$  denotes greater than or equal to. Dimensions in millimeters (mm).

**Example: IP44**=Ingress Protection; Solid bodies  $\geq$ 1.0 mm; Splashing

**IP44**  
Suitability

### Conversion Chart

Fractions to Decimals to Millimeters

Inches Fraction	Decimal	mm	Inches Fraction	Decimal	mm	Inches Fraction	Decimal	mm	Inches Fraction	Decimal	mm
1/64	0.0156	0.3969	17/64	0.2656	6.7469	33/64	0.5156	13.0969	49/64	0.7656	19.4469
1/32	0.0312	0.7938	9/32	0.2812	7.1438	17/32	0.5312	13.4938	25/32	0.7812	19.8437
3/64	0.0468	1.1906	19/64	0.2968	7.5406	35/64	0.5468	13.8906	51/64	0.7968	20.2406
1/16	0.0625	1.5875	5/16	0.3125	7.9375	9/16	0.5625	14.2875	13/16	0.8125	20.6375
5/64	0.0781	1.9844	21/64	0.3281	8.3344	37/64	0.5781	14.6844	53/64	0.8281	21.0344
3/32	0.0937	2.3812	11/32	0.3437	8.7312	19/32	0.5937	15.0812	27/32	0.8437	21.4312
7/64	0.1093	2.7781	23/64	0.3593	9.1281	39/64	0.6093	15.4781	55/64	0.8593	21.8281
1/8	0.1250	3.1750	3/8	0.3750	9.5250	5/8	0.6250	15.8750	7/8	0.8750	22.2250
9/64	0.1406	3.5719	25/64	0.3906	9.9219	41/64	0.6406	16.2719	57/64	0.8906	22.6219
5/32	0.1562	3.9688	13/32	0.4062	10.3188	21/32	0.6562	16.6688	29/32	0.9062	23.0188
11/64	0.1718	4.3656	27/64	0.4218	10.7156	43/64	0.6718	17.0656	59/64	0.9218	23.4156
3/16	0.1875	4.7625	7/16	0.4375	11.1125	11/16	0.6875	17.4625	15/16	0.9375	23.8125
13/64	0.2031	5.1594	29/64	0.4531	11.5094	45/64	0.7031	17.8594	61/64	0.9531	24.2094
7/32	0.2187	5.5562	15/32	0.4687	11.9062	23/32	0.7187	18.2562	31/32	0.9687	24.6062
15/64	0.2343	5.9531	31/64	0.4843	12.3031	47/64	0.7343	18.6531	63/64	0.9843	25.0031
1/4	0.2500	6.3500	1/2	0.5000	12.7000	3/4	0.7500	19.0500	1	1.0000	25.4000



## North American Watertight

Pg. J-14-19	Pg. J-20-24				Pg. J-3-7	Pg. J-8-13	Pg. J-25-28				Pg. J-35	
Fusible Safety Switches	Non-Fusible Safety Switches	Amps	Volts	Fusible Mec. Interlock	Non-Fusible Mec. Interlock	Plug	Receptacle	Connector	Inlet	Metallic Back Box	Non-Metallic Back Box	
N/A	N/A	20	120VAC				PS320P4W	PS320R4W	PS320C4W		PSBB201W	PSBBN201W
			240VAC				PS320P6W	PS320R6W	PS320C6W		PSBB201W	PSBBN201W
			480VAC				PS320P7W	PS320R7W	PS320C7W		PSBB201W	PSBBN201W
			277VAC				PS320P5W	PS320R5W	PS320C5W		PSBB201W	PSBBN201W
			120/240VAC	PS420FMIR12W	PS420MIR12W	PS420P12W	PS420R12W	PS420C12W		PSBB202W	PSBBN202W	
			3ø 240VAC	PS420FMIR9W	PS420MIR9W	PS420P9W	PS420R9W	PS420C9W		PSBB202W	PSBBN202W	
			3ø 480VAC	PS420FMIR7W	PS420MIR7W	PS420P7W	PS420R7W	PS420C7W		PSBB202W	PSBBN202W	
			3ø 600VAC	PS420FMIR5W	PS420MIR5W	PS420P5W	PS420R5W	PS420C5W		PSBB202W	PSBBN202W	
			3øY 120/208VAC			PS520P9W	PS520R9W	PS520C9W		PSBB202W	PSBBN202W	
			3øY 277/480VAC			PS520P7W	PS520R7W	PS520C7W		PSBB202W	PSBBN202W	
3øY 347/600VAC			PS520P5W	PS520R5W	PS520C5W		PSBB202W	PSBBN202W				
PS30FSS	PS30SS	30	120VAC		PS330MIR4W	PS330P4W	PS330R4W	PS330C4W		PSBB301W	PSBBN301W	
			240VAC	PS330FMIR6W		PS330P6W	PS330R6W	PS330C6W		PSBB301W	PSBBN301W	
			480VAC			PS330P7W	PS330R7W	PS330C7W		PSBB301W	PSBBN301W	
			120/240VAC	PS430FMIR12W	PS430MIR12W	PS430P12W	PS430R12W	PS430C12W		PSBB301W	PSBBN301W	
			3ø 240VAC	PS430FMIR9W	PS430MIR9W	PS430P9W	PS430R9W	PS430C9W		PSBB301W	PSBBN301W	
			3ø 480VAC	PS430FMIR7W	PS430MIR7W	PS430P7W	PS430R7W	PS430C7W		PSBB301W	PSBBN301W	
			3ø 600VAC	PS430FMIR5W	PS430MIR5W	PS430P5W	PS430R5W	PS430C5W		PSBB301W	PSBBN301W	
			380/440 VAC	PS430FMIR3W	PS430MIR3W	PS430P3W	PS430R3W	PS430C3W		PSBB301W	PSBBN301W	
			3øY 120/208VAC	PS530FMIR9W	PS530MIR9W	PS530P9W	PS530R9W	PS530C9W		PSBB301W	PSBBN301W	
			3øY 277/480VAC	PS530FMIR7W	PS530MIR7W	PS530P7W	PS530R7W	PS530C7W		PSBB301W	PSBBN301W	
3øY 347/600VAC	PS530FMIR5W	PS530MIR5W	PS530P5W	PS530R5W	PS530C5W		PSBB301W	PSBBN301W				
PS60FSS	PS60SS	60	120VAC			PS360P4W	PS360R4W	PS360C4W	PS360B4W	PSBB601W	PSBBN601W	
			240VAC	PS360FMIR6W	PS360MIR6W	PS360P6W	PS360R6W	PS360C6W	PS360B6W	PSBB601W	PSBBN601W	
			480VAC		PS360MIR7W	PS360P7W	PS360R7W	PS360C7W	PS360B7W	PSBB601W	PSBBN601W	
			120/240VAC	PS460FMIR12W	PS460MIR12W	PS460P12W	PS460R12W	PS460C12W	PS460B12W	PSBB601W	PSBBN601W	
			3ø 240VAC	PS460FMIR9W	PS460MIR9W	PS460P9W	PS460R9W	PS460C9W	PS460B9W	PSBB601W	PSBBN601W	
			3ø 480VAC	PS460FMIR7W	PS460MIR7W	PS460P7W	PS460R7W	PS460C7W	PS460B7W	PSBB601W	PSBBN601W	
			3ø 600VAC	PS460FMIR5W	PS460MIR5W	PS460P5W	PS460R5W	PS460C5W	PS460B5W	PSBB601W	PSBBN601W	
			3øY 120/208VAC	PS560FMIR9W	PS560MIR9W	PS560P9W	PS560R9W	PS560C9W	PS560B9W	PSBB601W	PSBBN601W	
			3øY 277/480VAC	PS560FMIR7W	PS560MIR7W	PS560P7W	PS560R7W	PS560C7W	PS560B7W	PSBB601W	PSBBN601W	
			3øY 347/600VAC	PS560FMIR5W	PS560MIR5W	PS560P5W	PS560R5W	PS560C5W	PS560B5W	PSBB601W	PSBBN601W	
PS100FSS	PS100SS	100	120VAC			PS3100P4W	PS3100R4W	PS3100C4W	PS3100B4W	PSBB1001W		
			240VAC		PS3100MIR6W	PS3100P6W	PS3100R6W	PS3100C6W	PS3100B6W	PSBB1001W		
			480VAC		PS3100MIR7W	PS3100P7W	PS3100R7W	PS3100C7W	PS3100B7W	PSBB1001W		
			120/240VAC	PS4100FMIR12W	PS4100MIR12W	PS4100P12W	PS4100R12W	PS4100C12W	PS4100B12W	PSBB1001W		
			3ø 240VAC	PS4100FMIR9W	PS4100MIR9W	PS4100P9W	PS4100R9W	PS4100C9W	PS4100B9W	PSBB1001W		
			3ø 480VAC	PS4100FMIR7W	PS4100MIR7W	PS4100P7W	PS4100R7W	PS4100C7W	PS4100B7W	PSBB1001W		
			3ø 600VAC	PS4100FMIR5W	PS4100MIR5W	PS4100P5W	PS4100R5W	PS4100C5W	PS4100B5W	PSBB1001W		
			3øY 120/208VAC	PS5100FMIR9W	PS5100MIR9W	PS5100P9W	PS5100R9W	PS5100C9W	PS5100B9W	PSBB1001W		
			3øY 277/480VAC	PS5100FMIR7W	PS5100MIR7W	PS5100P7W	PS5100R7W	PS5100C7W	PS5100B7W	PSBB1001W		
			3øY 347/600VAC	PS5100FMIR5W	PS5100MIR5W	PS5100P5W	PS5100R5W	PS5100C5W	PS5100B5W	PSBB1001W		

North American Splashproof

Amps	Volts	Pg. J-29				Pg. J-35	
		Plug	Receptacle	Connector	Inlet	Metallic Back Box	Non-Metallic Back Box
20	120VAC	PS320P4S	PS320R4S	PS320C4S	PS320B4S	PSBB201W	PSBBN201W
	240VAC	PS320P6S	PS320R6S	PS320C6S	PS320B6S	PSBB201W	PSBBN201W
	480VAC	PS320P7S	PS320R7S	PS320C7S	PS320B7S	PSBB201W	PSBBN201W
	277VAC	PS320P5S	PS320R5S	PS320C5S	PS320B5S	PSBB201W	PSBBN201W
	120/240VAC	PS420P12S	PS420R12S	PS420C12S	PS420B12S	PSBB202W	PSBBN202W
	3ø 240VAC	PS420P9S	PS420R9S	PS420C9S	PS420B9S	PSBB202W	PSBBN202W
	3ø 480VAC	PS420P7S	PS420R7S	PS420C7S	PS420B7S	PSBB202W	PSBBN202W
	3ø 600VAC	PS420P5S	PS420R5S	PS420C5S	PS420B5S	PSBB202W	PSBBN202W
	3øY 120/208VAC	PS520P9S	PS520R9S	PS520C9S	PS520B9S	PSBB202W	PSBBN202W
	3øY 277/480VAC	PS520P7S	PS520R7S	PS520C7S	PS520B7S	PSBB202W	PSBBN202W
3øY 347/600VAC	PS520P5S	PS520R5S	PS520C5S	PS520B5S	PSBB202W	PSBBN202W	
30	120VAC	PS330P4S	PS330R4S	PS330C4S	PS330B4S	PSBB301W	PSBBN301W
	240VAC	PS330P6S	PS330R6S	PS330C6S	PS330B6S	PSBB301W	PSBBN301W
	480VAC	PS330P7S	PS330R7S	PS330C7S	PS330B7S	PSBB301W	PSBBN301W
	120/240VAC	PS430P12S	PS430R12S	PS430C12S	PS430B12S	PSBB301W	PSBBN301W
	3ø 240VAC	PS430P9S	PS430R9S	PS430C9S	PS430B9S	PSBB301W	PSBBN301W
	3ø 480VAC	PS430P7S	PS430R7S	PS430C7S	PS430B7S	PSBB301W	PSBBN301W
	3ø 600VAC	PS430P5S	PS430R5S	PS430C5S	PS430B5S	PSBB301W	PSBBN301W
	3øY 120/208VAC	PS530P9S	PS530R9S	PS530C9S	PS530B9S	PSBB301W	PSBBN301W
	3øY 277/480VAC	PS530P7S	PS530R7S	PS530C7S	PS530B7S	PSBB301W	PSBBN301W
3øY 347/600VAC	PS530P5S	PS530R5S	PS530C5S	PS530B5S	PSBB301W	PSBBN301W	
60	120VAC	PS360P4S	PS360R4S	PS360C4S	PS360B4S	PSBB601W	PSBBN601W
	240VAC	PS360P6S	PS360R6S	PS360C6S	PS360B6S	PSBB601W	PSBBN601W
	480VAC	PS360P7S	PS360R7S	PS360C7S	PS360B7S	PSBB601W	PSBBN601W
	120/240VAC	PS460P12S	PS460R12S	PS460C12S	PS460B12S	PSBB601W	PSBBN601W
	3ø 240VAC	PS460P9S	PS460R9S	PS460C9S	PS460B9S	PSBB601W	PSBBN601W
	3ø 480VAC	PS460P7S	PS460R7S	PS460C7S	PS460B7S	PSBB601W	PSBBN601W
	3ø 600VAC	PS460P5S	PS460R5S	PS460C5S	PS460B5S	PSBB601W	PSBBN601W
	3øY 120/208VAC	PS560P9S	PS560R9S	PS560C9S	PS560B9S	PSBB601W	PSBBN601W
	3øY 277/480VAC	PS560P7S	PS560R7S	PS560C7S	PS560B7S	PSBB601W	PSBBN601W
3øY 347/600VAC	PS560P5S	PS560R5S	PS560C5S	PS560B5S	PSBB600W	PSBBN601W	

**International Watertight**

Amps	Volts	Pg. J-30				Pg. J-35	
		Receptacle	Plug	Surface Receptacle	Connector	Inlet	Non-Metallic Back Box
16	110/120	51925 with box	51955	51925	51985		52029
	220/240	51126 with box	52046	51126	52086		52029
	380/415						
	220/240						
	380/415	52227 with box	52247	52227	52287		52229
	440						
	500						
	220/240						
	220/380; 240/415	51131	51161	51131	51181		52229
32	110/120	51926 with box	51946	51926	51986		
	220/240	52726 with box	52746	52726	52786		
	380/415						
	220/240						
	380/415	52927 with box	52947	52927	52987		
	440						
	500						
	220/240						
	220/380; 240/415	52928 with box	52948	52928	52988		
63	110/120						
	220/240	53626	53646	53636	53686		53889
	220/240	53627	53647	53637	53687		53889
	380/415	53827	53847	53837	53887		53889
	500	53727	53747	53737	53787		53889
	220/240	53628	53648	53638	53688		53889
	220/380; 240/415	53828	53848	53838	53888		53889
125	380/415	59112	59122	59102	59132	59142	
	220/380; 240/415	59113	59123	59103	59133	59143	

**International Splashproof**

Amps	Volts	Pg. J-30				Pg. J-35	
		Receptacle	Plug	Surface Receptacle	Non-Metallic Connector	Inlet	Back Box
16	110/120	51920 with box	51940	51920	51980	51970	52029
	220/240	52022 with box	52042	52022	52082	52172	52029
	380/415	52222 with box	52242	52222	52282	52272	52029
	220/240	52023 with box	52043	52023	52083	52073	52229
	380/415	52223 with box	52243	52223	52283	52173	52229
	440	52310 with box	52311	52310	52312		52229
	500	52320 with box	52321	52320	52322		52229
	220/240	52024 with box	52044	52024	52084	52074	52229
		220/380; 240/415	52224 with box	52244	52224	52284	52174
32	110/120					51972	
	220/240	52722 with box	52742	52722	52782	52872	
	380/415	52922 with box	52942	52922	52982	52972	
	220/240	52723 with box	52743	52723	52783	52773	
	380/415	52923 with box	52943	52923	52983	52873	
	440	52350 with box	52351	52350	52352		
	500	52360 with box	52361	52360	52362		
	220/240	52724 with box	52744	52724	52784	52774	
		220/380; 240/415	52924 with box	52944	52924	52984	52874
63	110/120	53542	53582	53522			53889
	220/240	53622	53642	53722	53682	53772	53889
	220/240	53623	53643	53633	53683		53889
	380/415	53823	53843	53723	53883	53773	53889
	500						53889
	220/240	53624	53644	53634	53684		53889
		220/380; 240/415	53824	53844	53724	53884	53774